

## Showmanship Quali LK 1/2 A+B

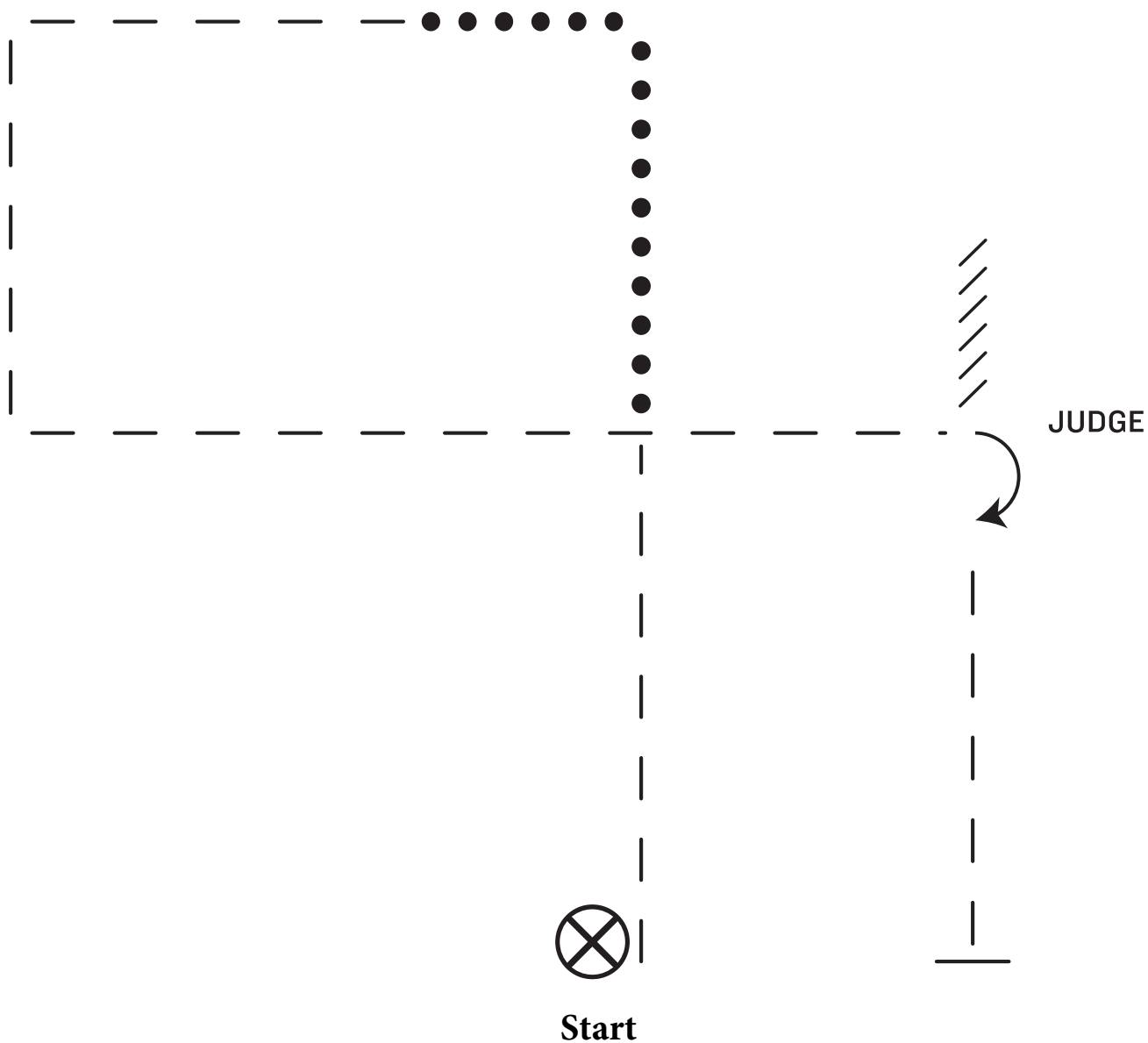

1. Trot until even with judge
2. Walk for 3 horse lengths and walk a corner
3. Trot 3 horse lengths and trot a corner, continue trotting and trot corner to judge
4. Stop and set up for inspection
5. When excused, do a 90° turn
6. Back 1 horse length
7. Exit at a walk or trot

## Showmanship LK 1+2A

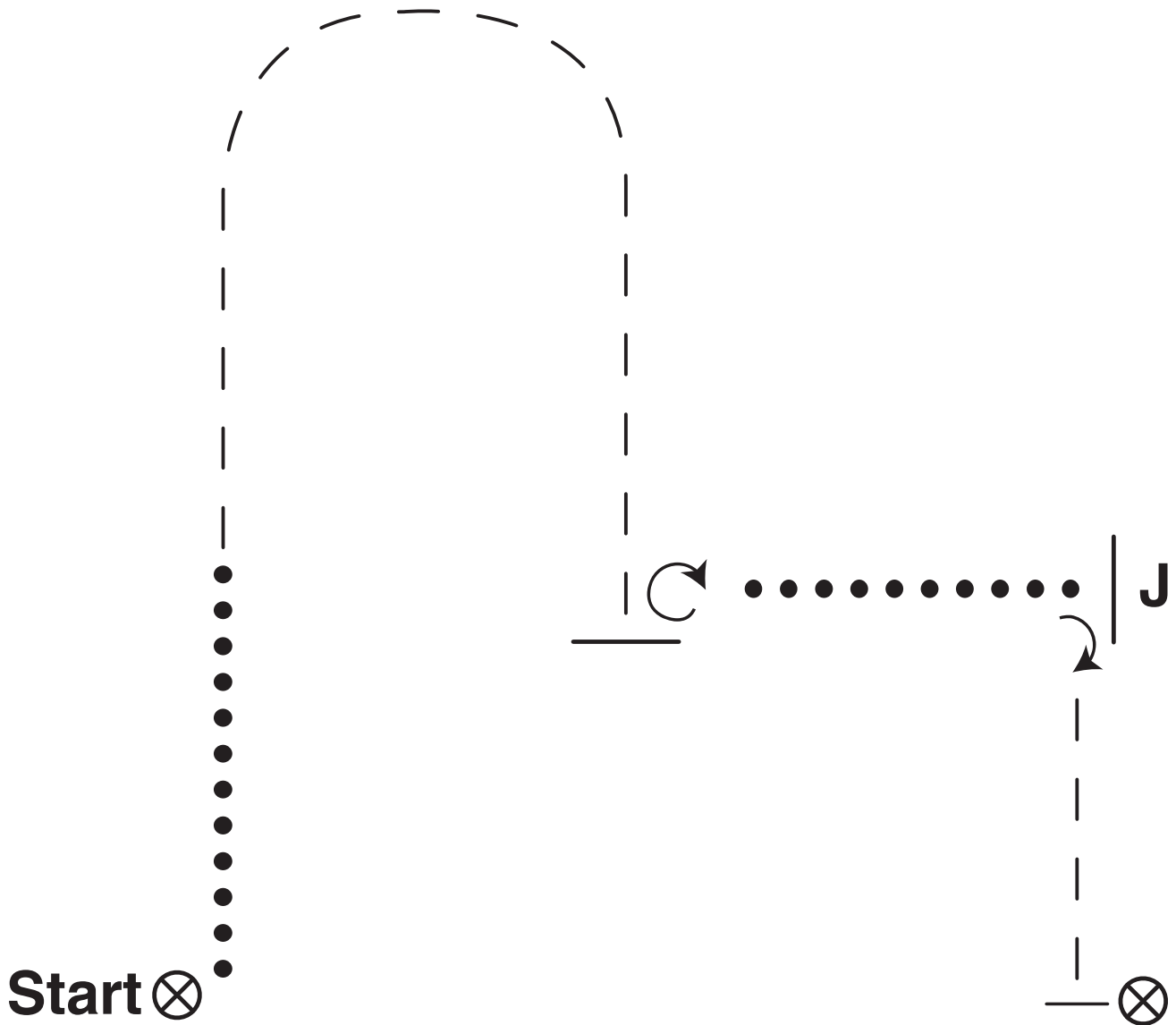

1. Walk 1/2 line
2. Trot around end and down line
3. Halt and execute a 1/3 turn
4. Walk to judge
5. Set up for inspection
6. After inspection, 1/4 turn and trot to marker, stop
7. Exit at a walk or trot

## Showmanship LK 3A

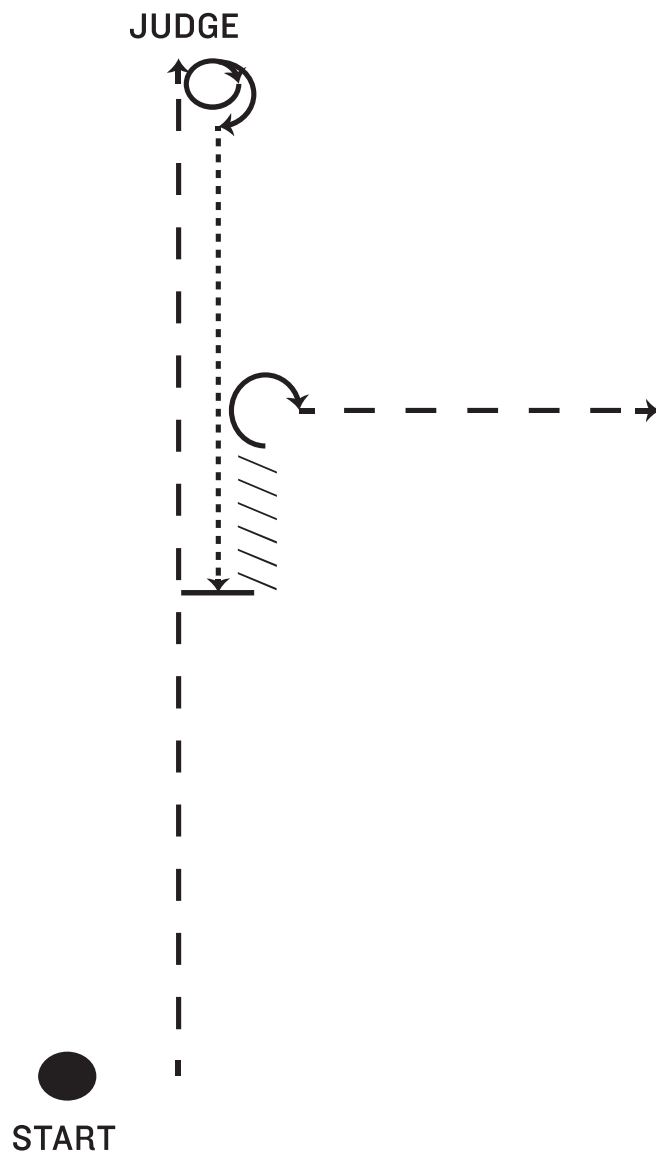

1. Trot to judge
2. Set up for full inspection
3. After inspection, execute 1 1/2 turns and walk half of line
4. Stop, back 2 horse lengths
5. 3/4 turn and trot
6. Halt and set-up. When set up is complete, exit at a walk or jog



**LK 1/2 A jun RR**

Pattern RR #9: LK 1/2 A/B jun.

Arenagröße: mind. 20x40m

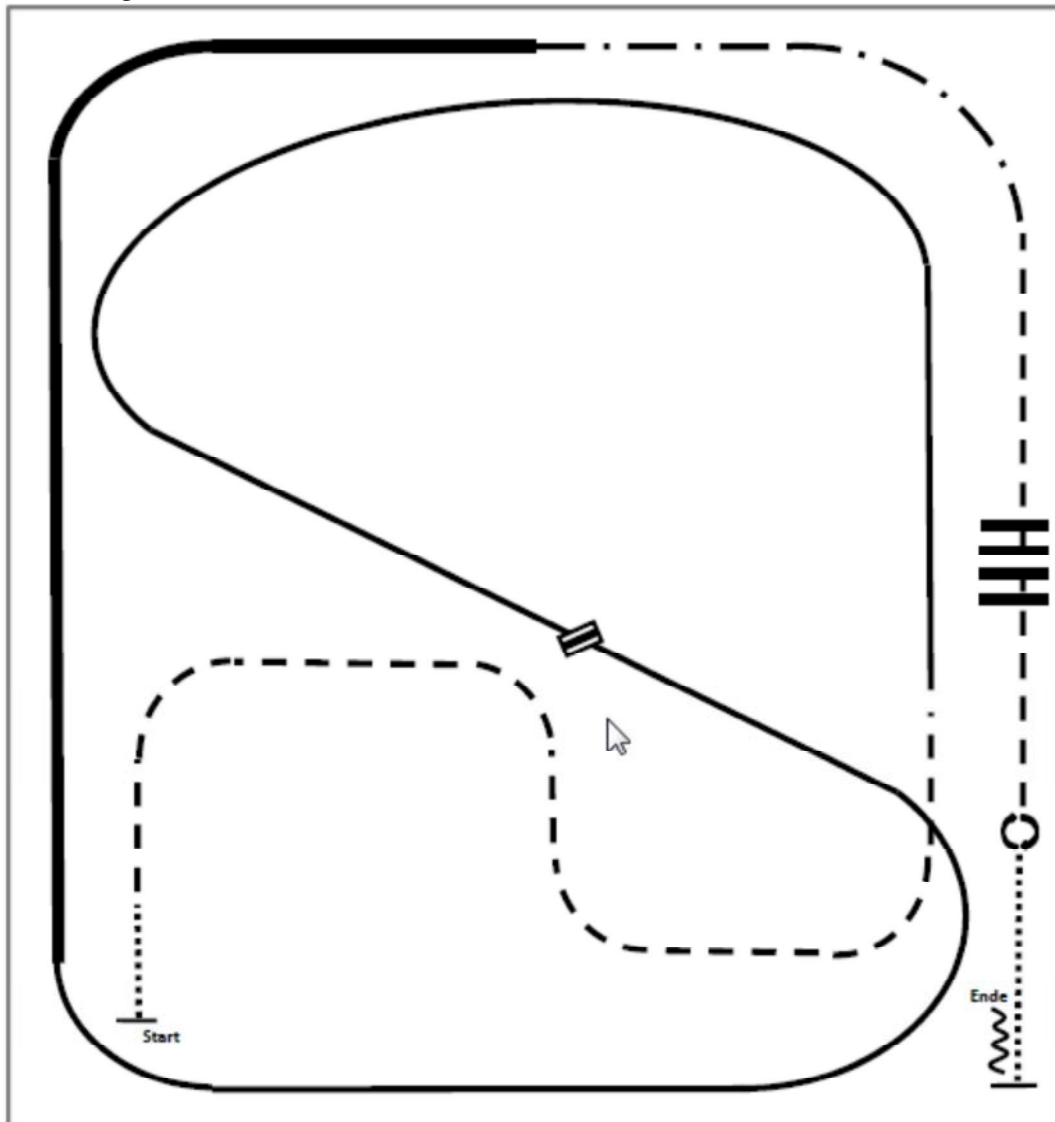

1. Walk
2. Trot
3. Lope left lead
4. Change leads
5. Lope right lead
6. Ext. Lope right lead
7. Ext. Trot
8. Trot
9. Trot over
10. Stop, Turn 360° each direction (either way first)
11. Walk, Stop, Back

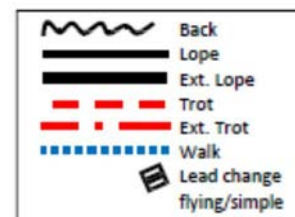

**Quali LK 1/2 A jun RR**

Pattern RR #13: LK 1/2 A/B jun.

Arenagröße: mind. 20x40m

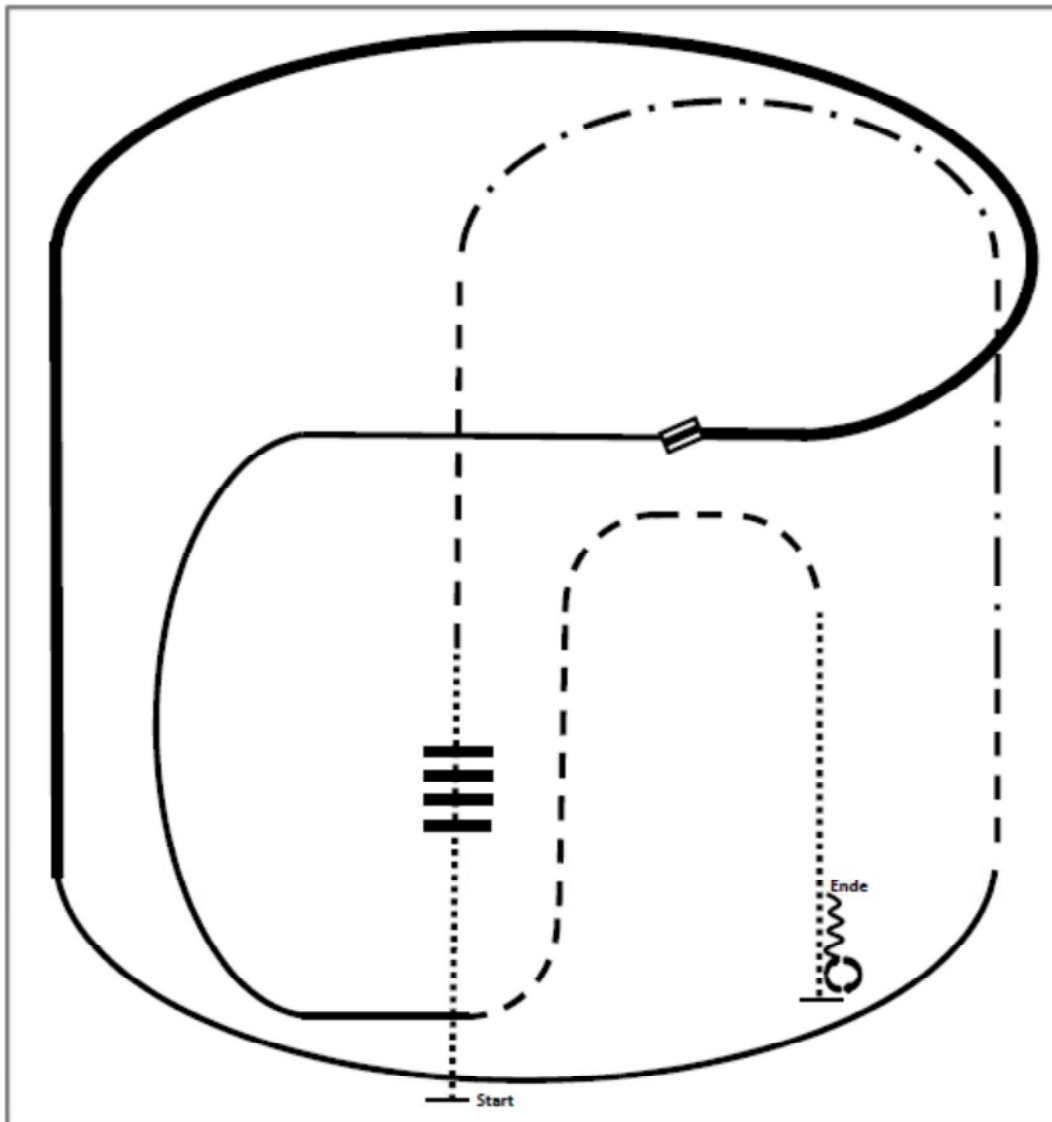

1. Walk over
2. Trot
3. Ext.Trot, Trot
4. Lope right lead
5. Ext. Lope right lead
6. Change leads
7. Lope left lead
8. Trot
9. Walk
10. Stop, Turn 360° each direction (either way first)
11. Back

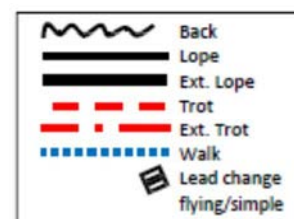

**LK 1/2 A+B sen RR**

Pattern RR #6: LK 1/2 A/B sen. Quali

Arenagröße: mind. 20x40m

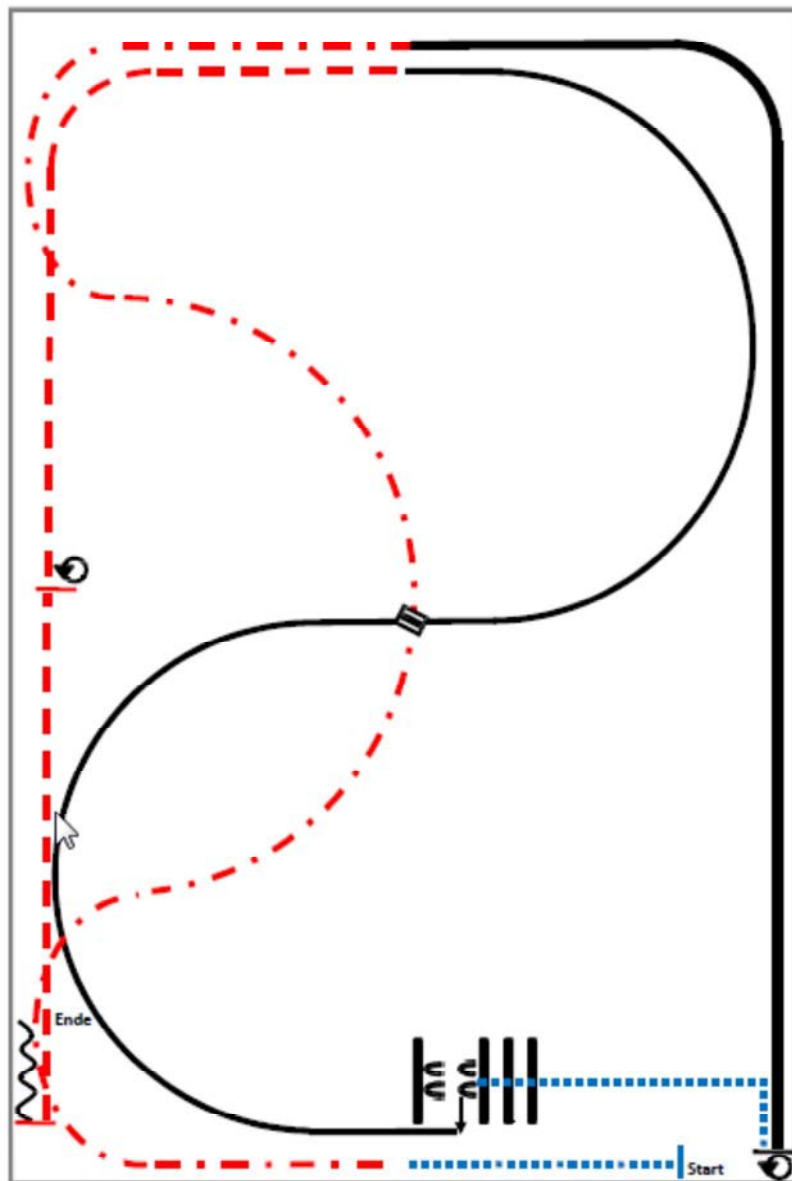

- 1) Walk.
- 2) Extended trot serpentines.
- 3) Extended lope right lead.
- 4) Stop, 180° turn right.
- 5) Walk.
- 6) Walkover, sidepass left.
- 7) Lope right lead.
- 8) Leadchange.
- 9) Lope left lead.
- 10) Trot.
- 11) Stop, 360° turns each direction either way first.
- 12) Trot, stop, back.

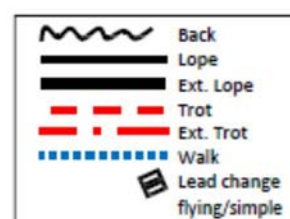











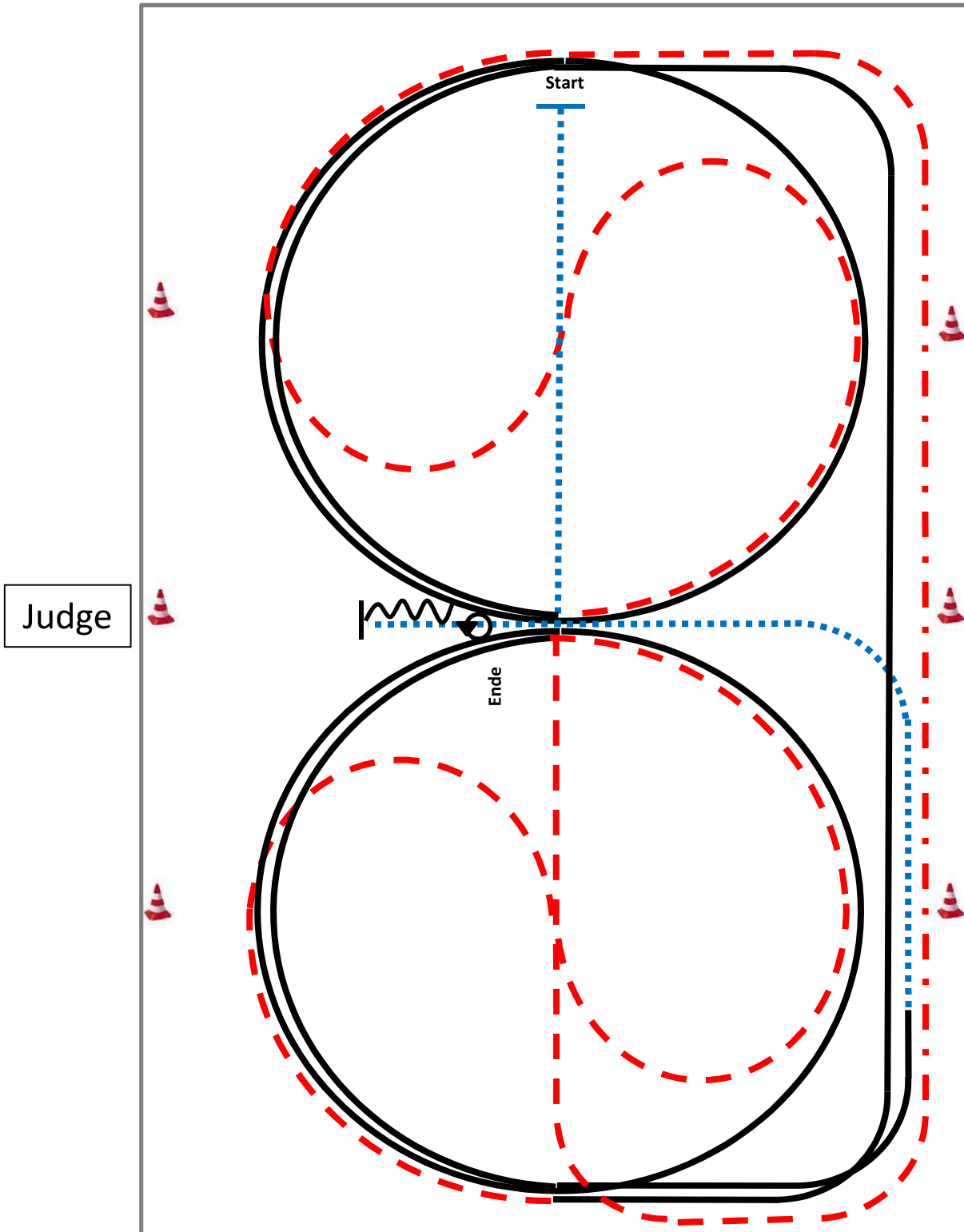

## Jupf Basis Pattern 2 (4j./5j.)



- 1) Schritt durch die Länge der Bahn, bei X antraben, ganze Bahn, an der langen Seite Tritte verlängern (Leichttraben erlaubt).
- 2) Trab, Mitte der kurzen Seite auf dem Zirkel geritten, durch den Zirkel wechseln.
- 3) Bei X Rechtsgalopp 1½ Zirkel, Mitte der kurzen Seite ganze Bahn.
- 4) Mitte der kurzen Seite Trab auf dem Zirkel geritten, durch den Zirkel wechseln.
- 5) Bei X Linksgalopp 1½ Zirkel, Mitte der kurzen Seite ganze Bahn.
- 6) Nach durchreiten der Ecke Schritt, Mitte der langen Seite abwenden, nach X anhalten, Rückwärtsrichten bis X, HHW 360° li..

Verharren, um das Ende der Prüfung anzuzeigen.



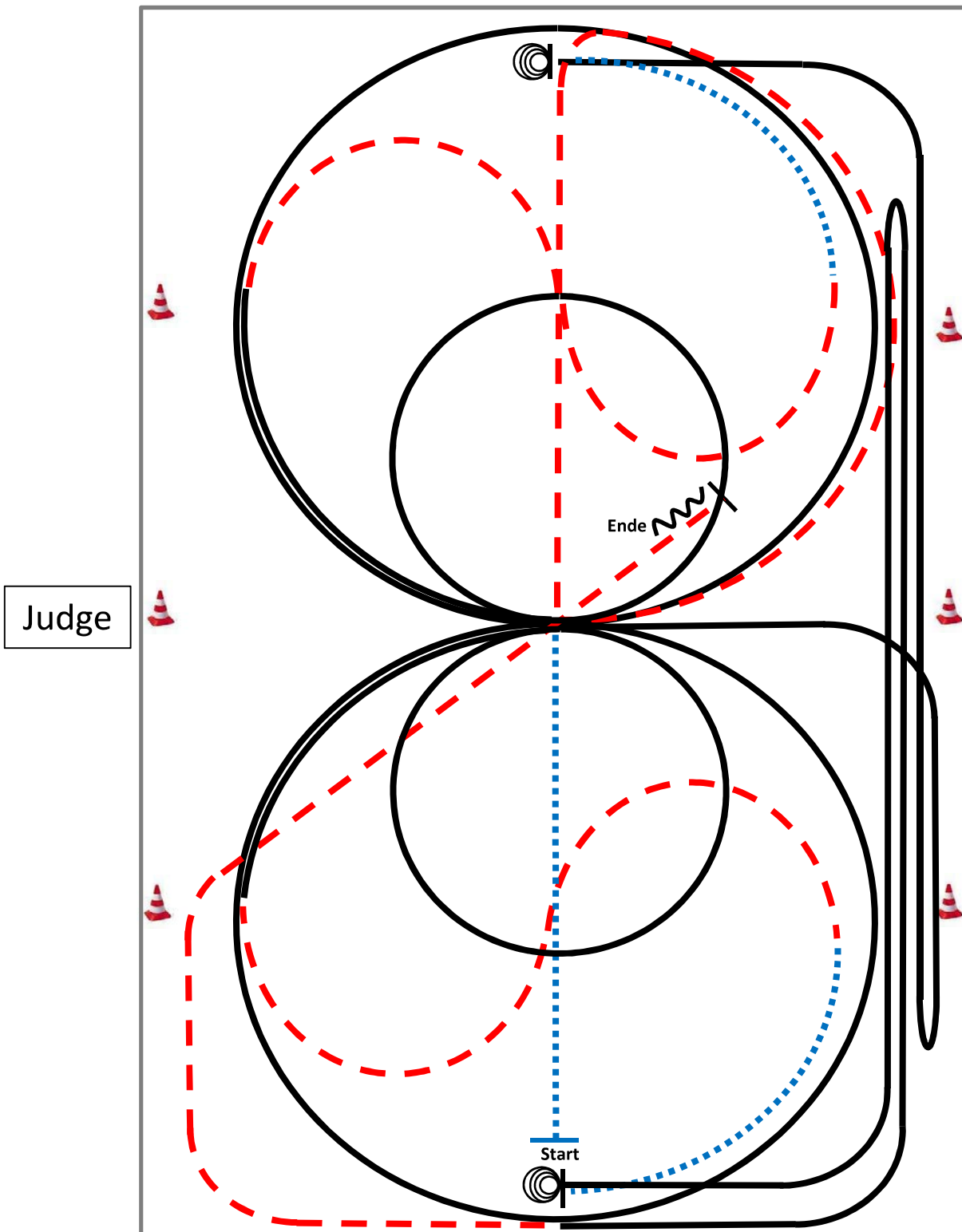

	Rückwärts
	Galopp
	Trab
	Schritt

## Jupf Reining Pattern 2 (4.j./5j.)



- 1) Schritt und Trab durch die Länge der Bahn, Trab  $\frac{1}{4}$  Zirkel, 2 Zirkel Galopp (**rechts**), 1.groß und schnell, 2.klein und langsam.
- 2) Weiter  $\frac{1}{4}$  Zirkel, Trab durch den Zirkel wechseln, Schritt bis Mitte kurze Seite.
- 3)  $3\frac{1}{2}$  Spins **rechts**, verharren.
- 4) Galopp (**rechts**) auf dem Zirkel, der nicht geschlossen wird, run down entlang der langen Seite, sliding stop mind. 6m von der Bande entfernt hinter dem **Endmarker**, rollback **links**, kein Verharren, Galopp bis X.
- 5) 2 Zirkel Galopp (**links**), 1.groß und schnell, 2.klein und langsam, weiter  $\frac{1}{4}$  Zirkel, Trab durch den Zirkel wechseln, Schritt bis Mitte kurze Seite.
- 6)  $3\frac{1}{2}$  Spins **links**, verharren.
- 7) Galopp (**links**) auf dem Zirkel, der nicht geschlossen wird, run down entlang der langen Seite, sliding stop mind. 6m von der Bande entfernt, hinter dem **Endmarker**, rollback **rechts**, kein Verharren, Galopp bis Mitte kurze Seite.
- 8) Trab, auf der Diagonalen, hinter X stop, Rückwärtsrichten mind. 3m, verharren.



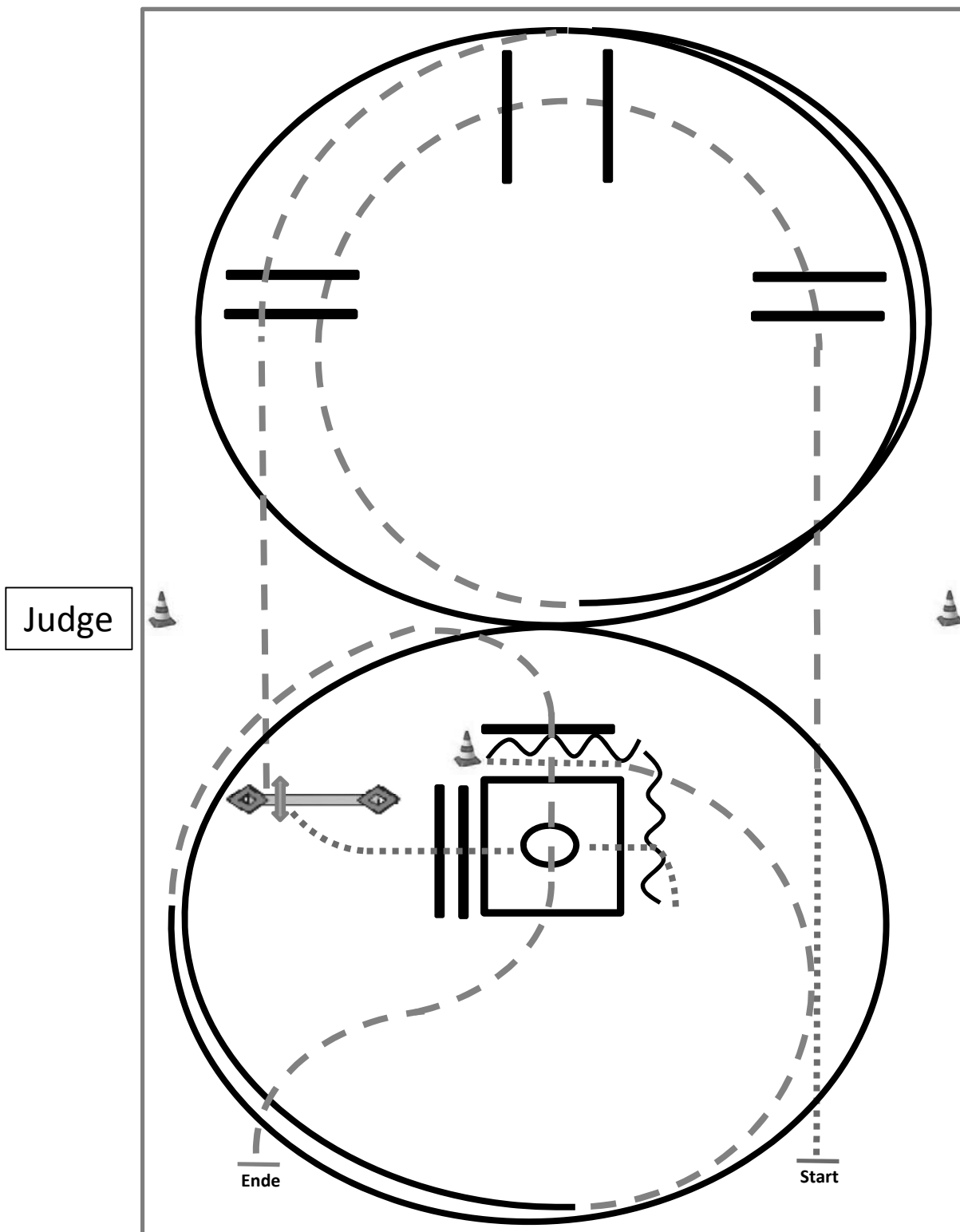

Der Reiter muss das Kopfstück zur Gebisskontrolle vor dem Richter abnehmen.

	Rückwärts
	Galopp
	Trab
	Schritt

# Jupf Trail Pattern 4 (4j.)





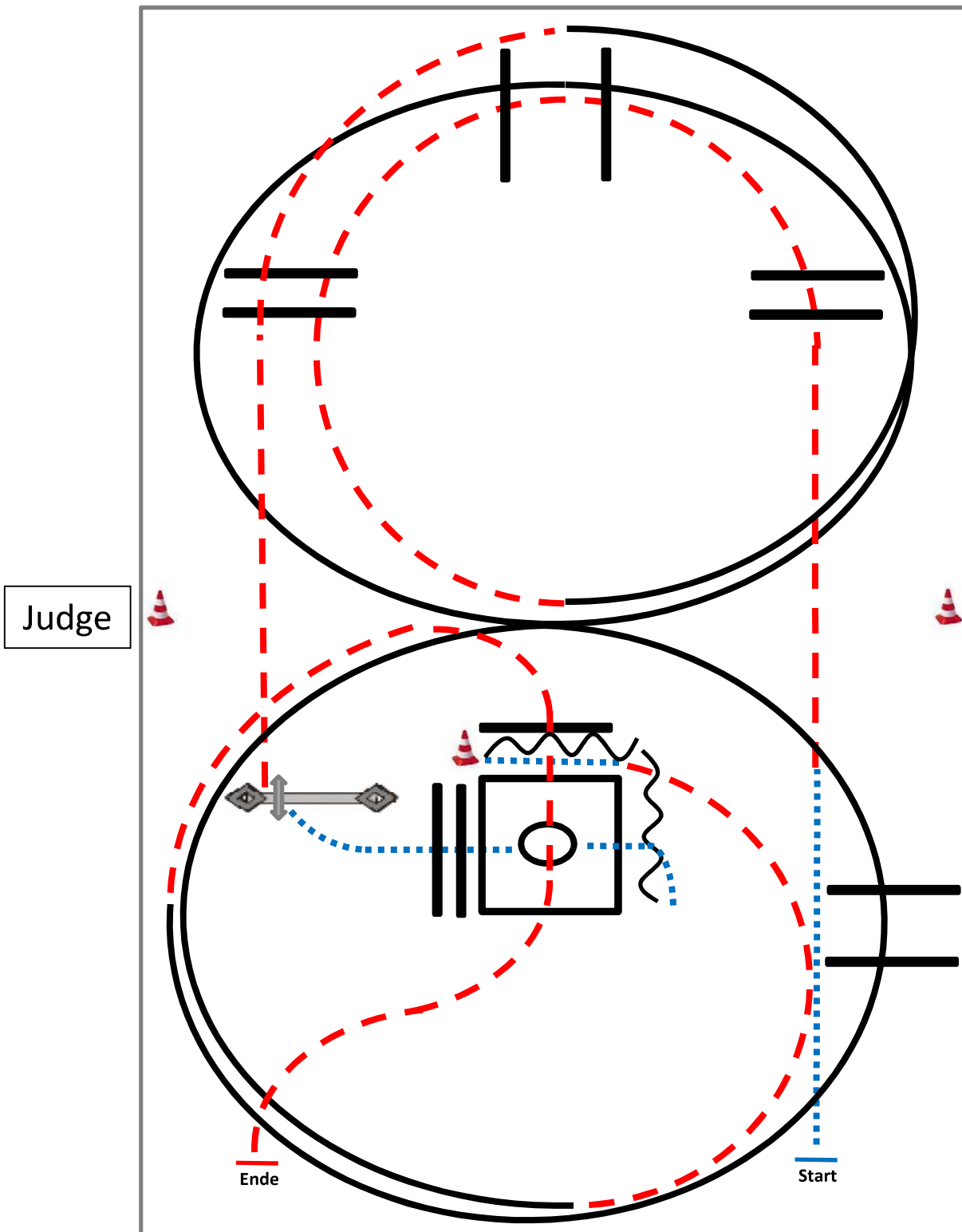

- 1) Schritt, Trab, Trabstangen (Abstand: 1m/2m/1m).
- 2) Linksgalopp 1½ Zirkel, Trabstangen.
- 3) Tor.
- 4) Schritt, Schrittstangen (Abstand: 0,6m), Box 360 re.o.li., Schritt.
- 5) Rückwärtsrichten L (Abstand: 1m), Schritt, Trab ½ Zirkel.
- 6) Rechtsgalopp 1¼ Zirkel, Trabstangen, anhalten.

	Rückwärts
	Galopp
	Trab
	Schritt

# Jupf Trail Pattern 5 (5j.)



- 1) Schritt, Trab, Trabstangen (Abstand: 1m/2m/1m).
- 2) Linksgalopp inkl. Galoppstangen, 1½ Zirkel, Trabstangen.
- 3) Tor.
- 4) Schritt, Schrittstangen (Abstand: 0,6m), Box 360 re.o.li, Schritt.
- 5) Rückwärtsrichten L (Abstand: 1m), Schritt, Trab ½ Zirkel.
- 6) Rechtsgalopp 1¼ Zirkel inkl. Galoppstangen (Abstand: 2m), Trabstangen, anhalten.

	Rückwärts
	Galopp
	Trab
	Schritt



Trail

Kat. A/B

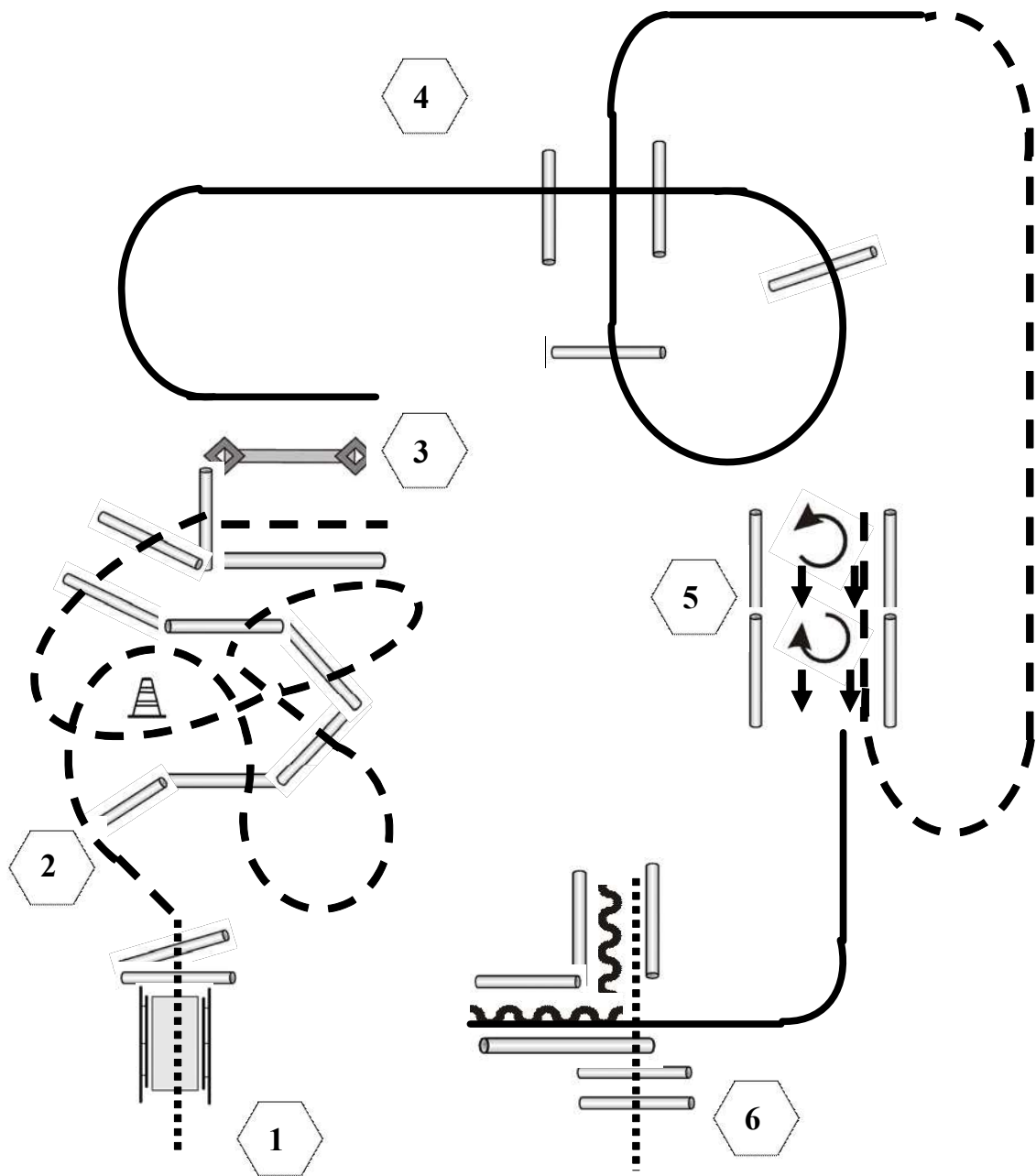
LK 1





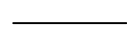

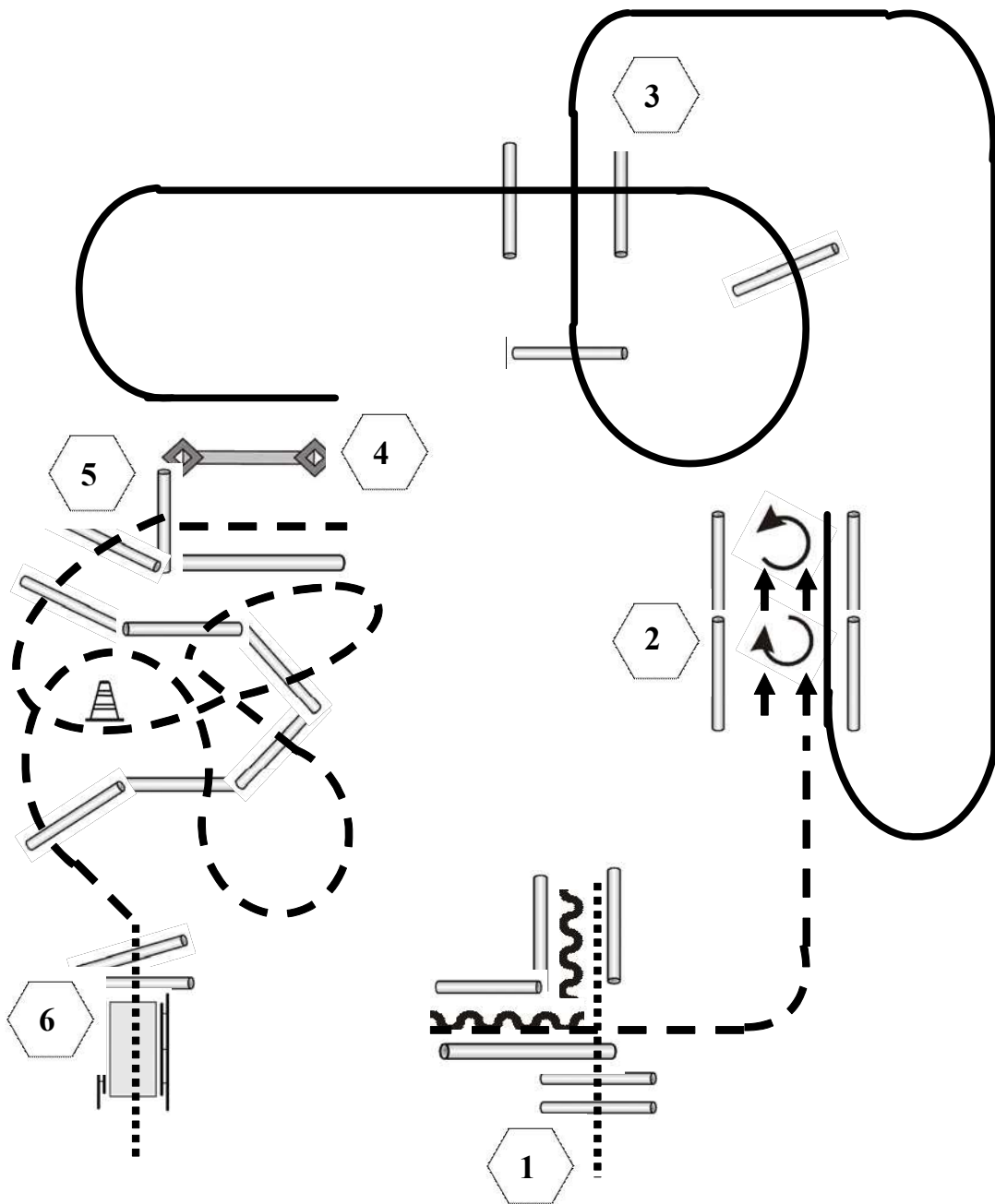
1. Brücke.
2. Jog-Over-Stangen
3. Jog In, Tor
4. Lope-Over-Stangen
5. Jog In, 90° HHW links, Sidepass, 180° HHW rechts, sidepass
6. Lope In, Back Up, Walk-Over-Stangen

- |   |         |
|---|---------|
|  | Back Up |
|  | Walk    |
|  | Jog     |
|  | Lope    |





1. Walk Over, Back Up, Jog Out
2. Sidepass rechts, 180° HHW rechts, Sidepass links, 270° HHW links,
3. Lope Over-Stangen
4. Tor
5. Jog-Over-Stangen
6. Walk Over, Brücke

	Back Up
	Walk
	Jog
	Lope

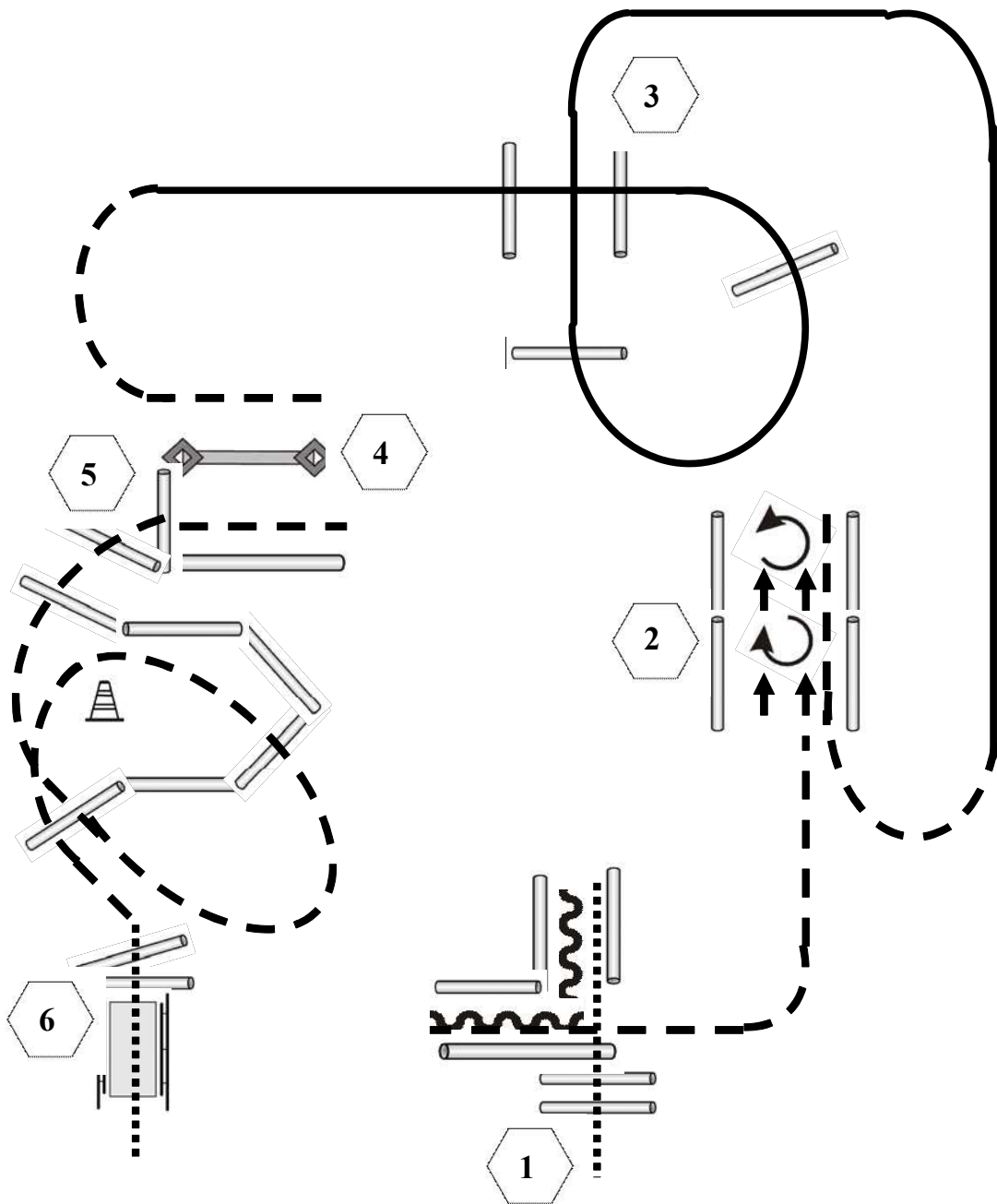



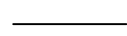

1. Walk Over, Back Up, Jog Out
2. Sidepass rechts, 180° HHW rechts, Sidepass links, 270° HHW links,
3. Lope Over-Stangen
4. Tor
5. Jog-Over-Stangen
6. Walk Over, Brücke

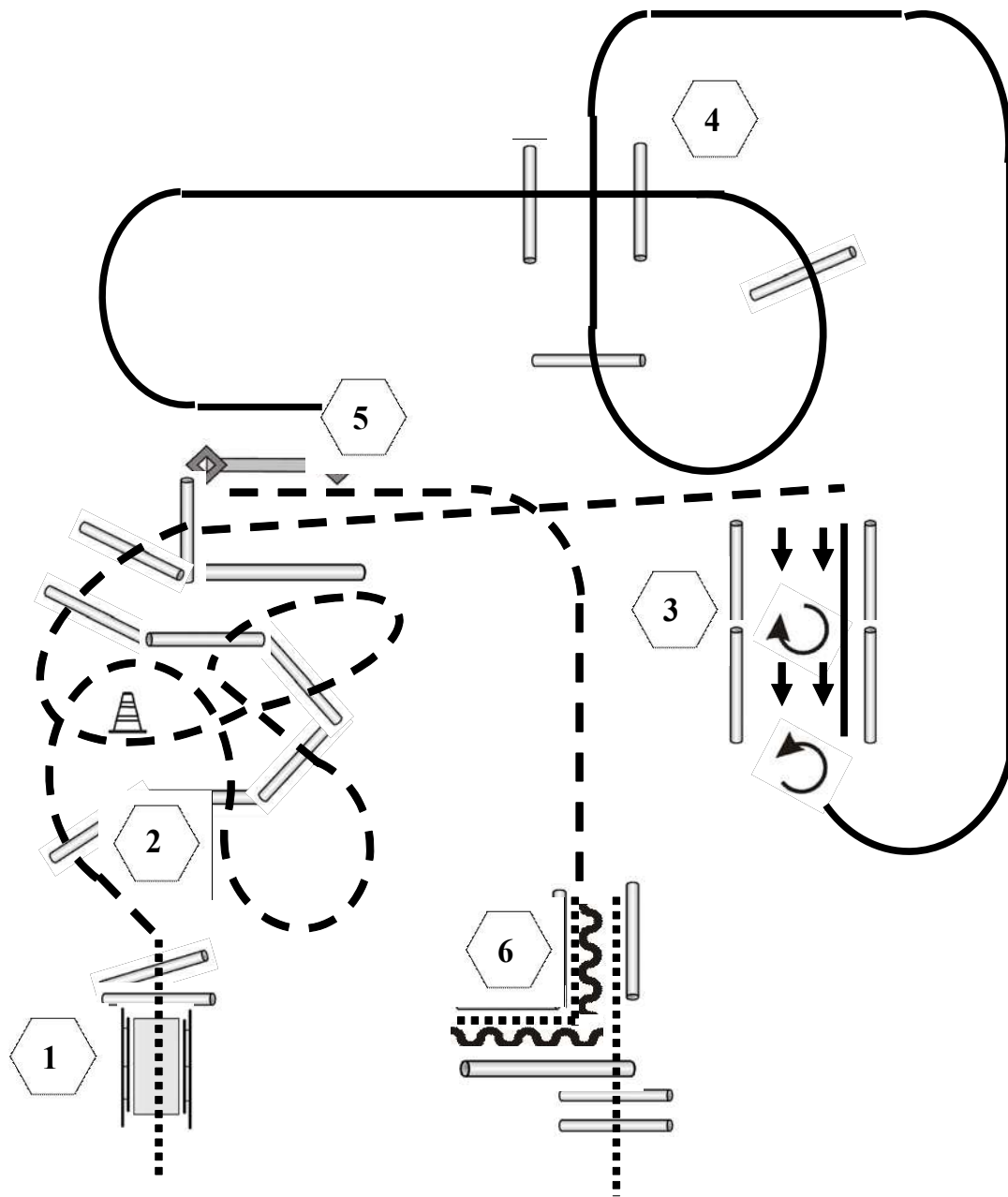
- |   |         |
|---|---------|
|  | Back Up |
|  | Walk    |
|  | Jog     |
|  | Lope    |





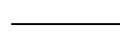

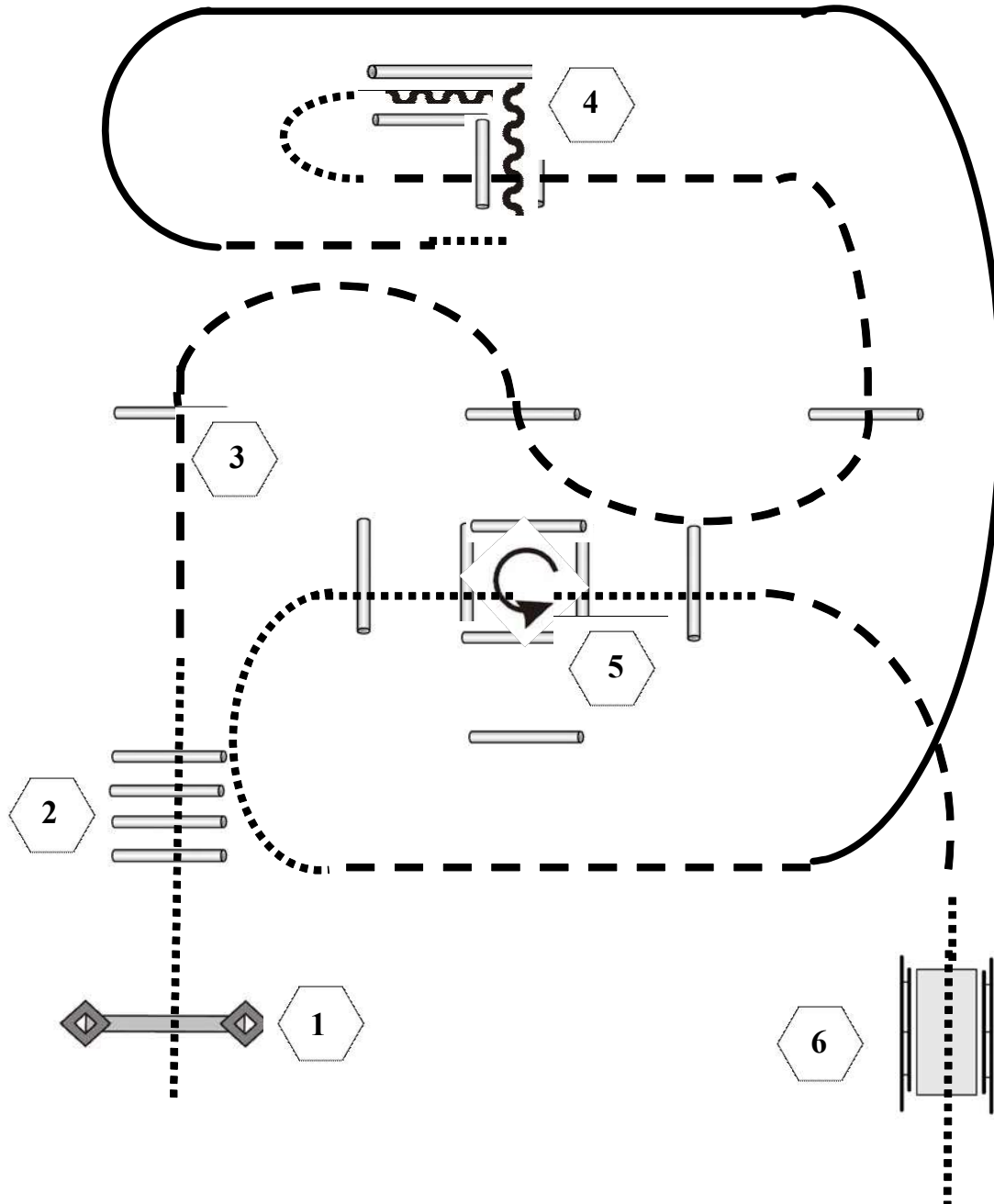
1. Brücke, Walk Over
2. Jog Over
3. Sidepass rechts, 180° rechts, Sidepass links, 180° links
4. Lope Over
5. Tor
6. Walk In, Back Up, Walk Out

- |   |         |
|---|---------|
|  | Back Up |
|  | Walk    |
|  | Jog     |
|  | Lope    |

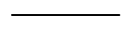

1. Tor
2. Walk Over
3. Jog Over
4. Back Up
5. Walk In, 360° Drehung links, Walk Out
6. Brücke

- |   |          |
|---|----------|
|  | Back Up  |
|  | Walk     |
|  | Jog      |
|  | Lope     |
|  | Wechsel  |
|  | Erhöhung |

- 1 JOG OVERS INTO CHUTE
- 2 STOP IN CHUTE BACK TO GATE
- 3 RH GATE OPEN RIDE THRU CLOSE-JOG OUT
- 4 JOG OVERS
- 5 STOP OR BREAK TO A WALK-WALK OVERS-BRIDGE--WALK OVERS
- 6 LL LOPE OVERS
- 7 JOG OVERS
- 8 RL LOPE OVERS
- 9 LOPE IN CHUTE-STOP OR BREAK TO A WALK  
WALK OVER POLE-SIDEPASS 2ND POLE  
END OF PATTERN

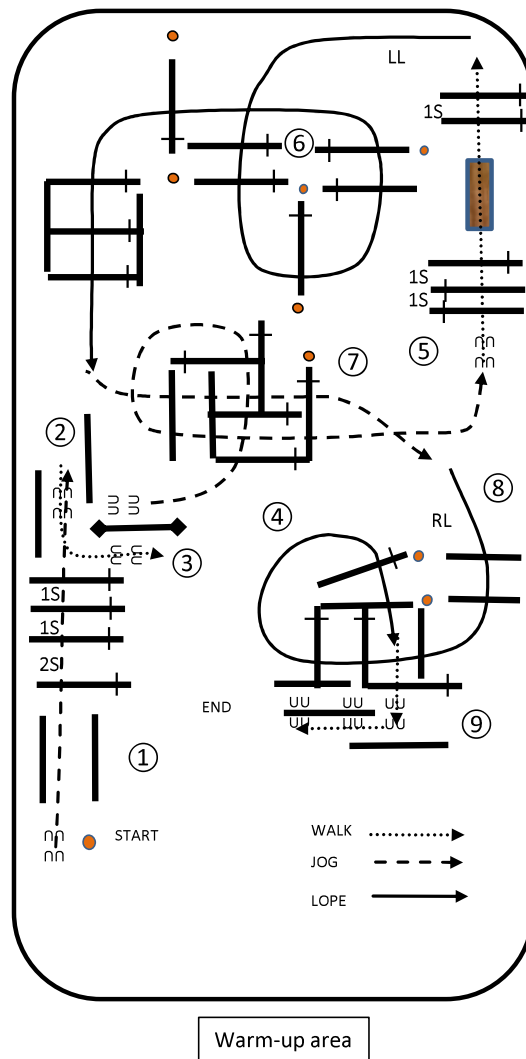

- 1 JOG OVERS INTO CHUTE
- 2 STOP IN CHUTE BACK TO GATE
- 3 RH GATE OPEN RIDE THRU CLOSE-JOG OUT
- 4 JOG OVERS
- 5 STOP OR BREAK TO A WALK-WALK OVERS-  
BRIDGE-WALK OVERS
- 6 LL LOPE OVERS
- 7 JOG OVERS
- 8 RL LOPE OVERS
- 9 LOPE IN CHUTE-STOP OR BREAK TO A WALK  
WALK OVERS  
END OF PATTERN

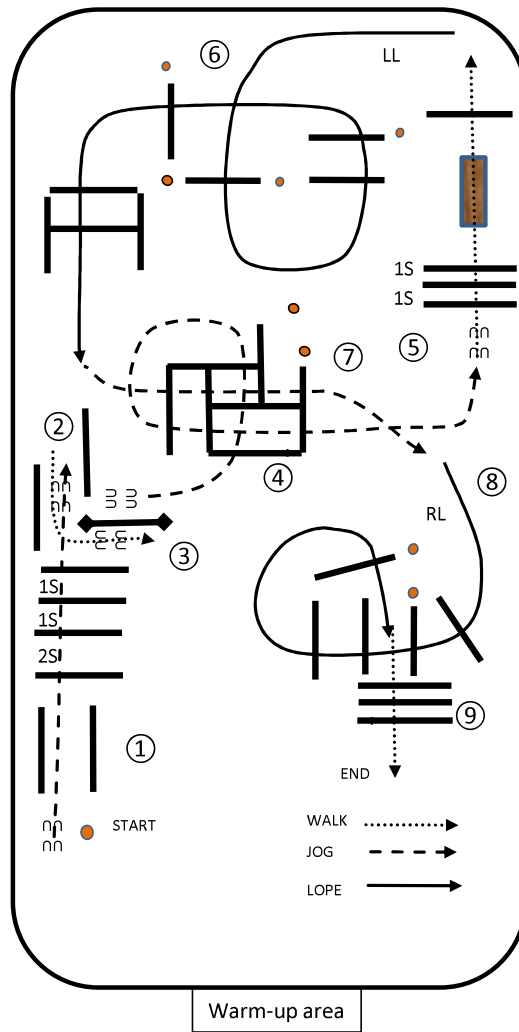

# Circle L Wenden Classic

## Western Horsemanship LK 4/5 B + A

w w w . H o r s e S h o w P a t t e r n s . c o m

w w w . H o r s e S h o w P a t t e r n s . c o m

1. Jog A to B
2. At B jog a circle to the left
3. At B lope a circle to the right on the right lead
4. Continue the lope to C
5. At C stop

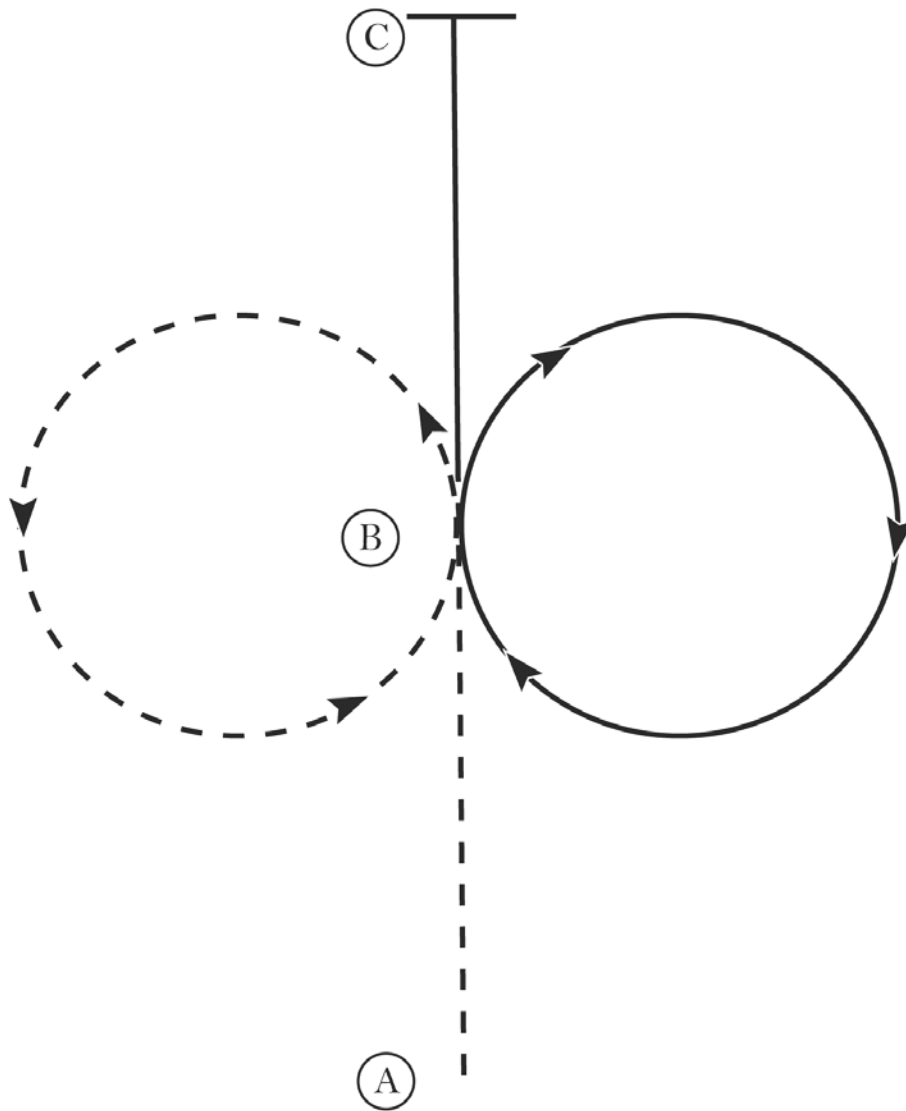

Walk	.....
Jog	-----
Extended Jog	-----
Lope	—————
Leg Yield	
Lead Change	↘
Back	←←←←← ←←←←←
Marker	(B)
Sidepass	←-----←

[WH/1-9]

Pattern Provided by:

*Reitverein Wenden e.V.*

# Circle L Wenden Classic

## Western Horsemanship LK 3 A+B

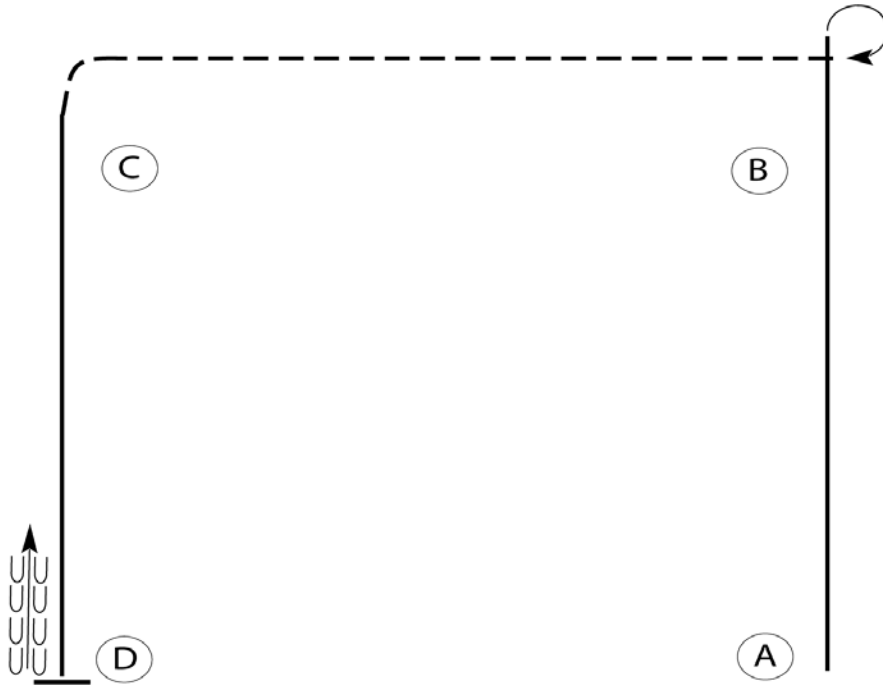

Be ready at A.

1. Lope on the right lead from A to B.
2. Stop past B and execute a 270 degree turn to the right.
3. Jog from B around C.
4. Lope on the left lead from C to D.
5. Stop at D and back one horse length.

Please exit at a jog.

Walk	-----
Jog	- - - - -
Extended Jog	- - - - -
Lope	—————
Leg Yield	
Lead Change	— / —
Back	← ← ← ← ←
Marker	⊙ B
Sidepass	← — — — — →

[WH/2-23]

Pattern Provided by:

*Reitverein Wenden e.V.*

# Circle L Wenden Classic

## Western Horsemanship LK 1+2 A+B

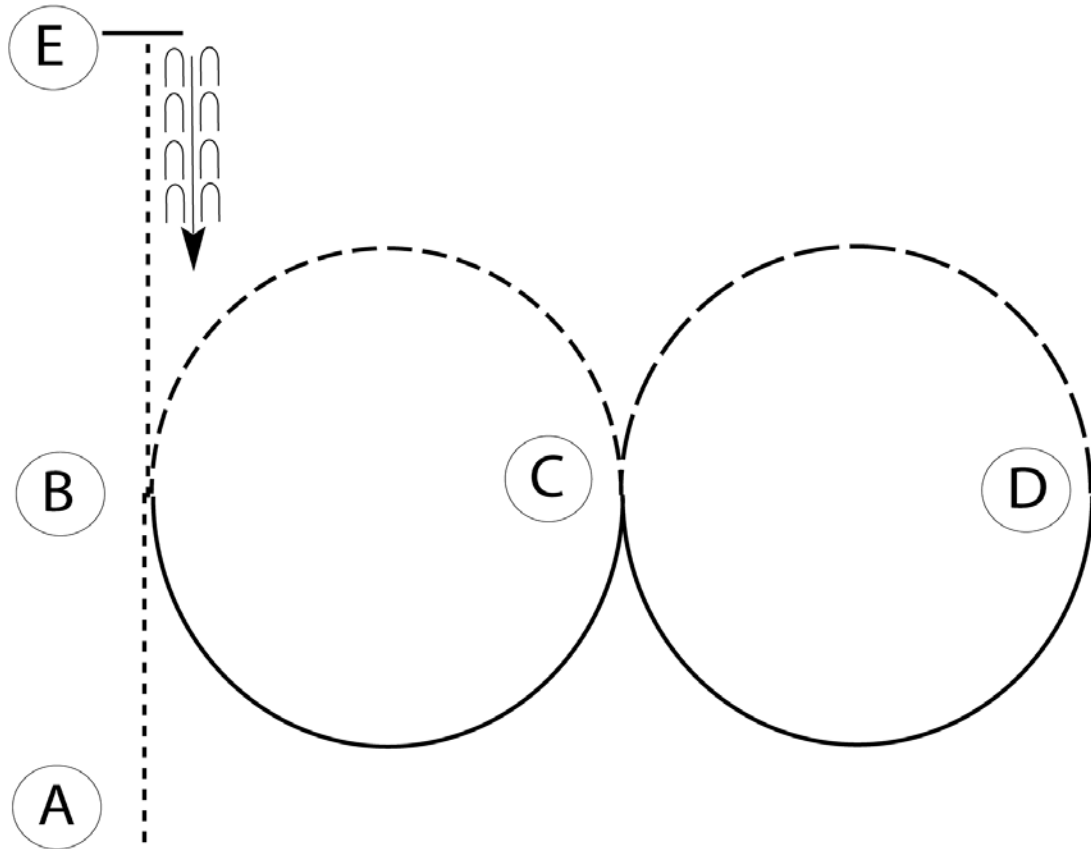

Be ready at A.

1. Walk A to B.
2. Jog a half circle to C.
3. Lope a half circle on the left lead to D.
4. Extend the jog in a half circle to C.
5. Lope a half circle on the right lead to B.
6. Walk to E.
7. Stop at E and back approximately one horse length.

Follow the instructions of your ring steward.

Walk	.....
Jog	-----
Extended Jog	-----
Lope	—————
Lead Change	———/———
Back	←———
Marker	(B)

[WH/2-3]

Pattern Provided by:

*Reitverein Wenden e.V.*



# Quali Pattern LK 1/2 A



## Q-Pattern 15: WHS LK 1/2 A/B

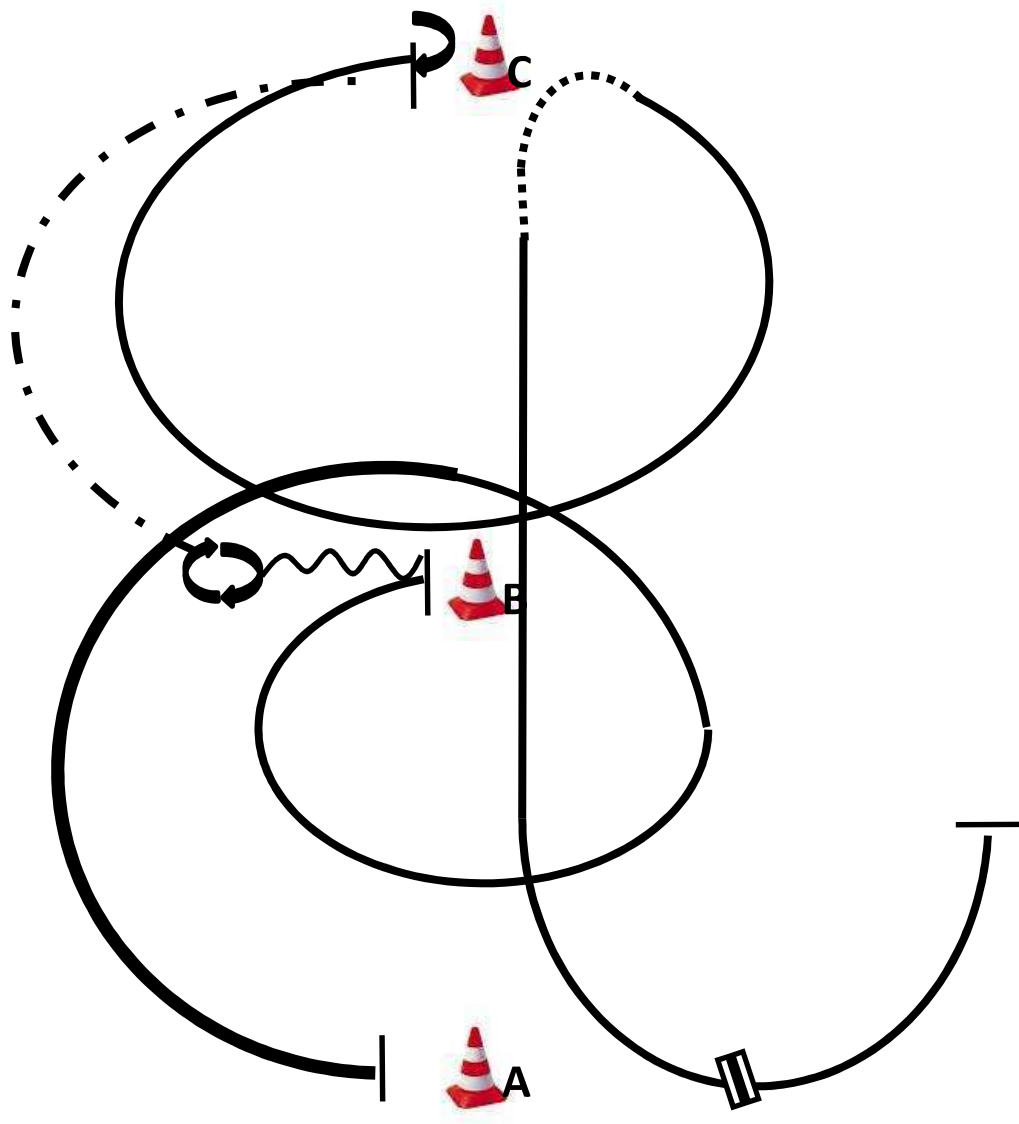

Start

WARM UP AREA

1. Be ready at A (A is behind you), lope right lead around B, the first half circle ext. Lope.
2. The second half circle collected Lope, stop in front of B.
3. Back one horse length.
4. 540° turn (opt. r/l).

5. Ext. Jog to C, stop in front of C.
  6. 180° turn (opt. r/l), Lope left lead.
  7. Walk, lope right lead.
  8. Lead change, lope left lead, stop.
- Walk to warm up area.

	Back
	Lope
	ext. Lope
	Jog
	Ext. Jog
	Walk
	Lead change flying/simple

# Quali Pattern LK 1/2 B



## Q-Pattern 17: WHS LK 1/2 A/B

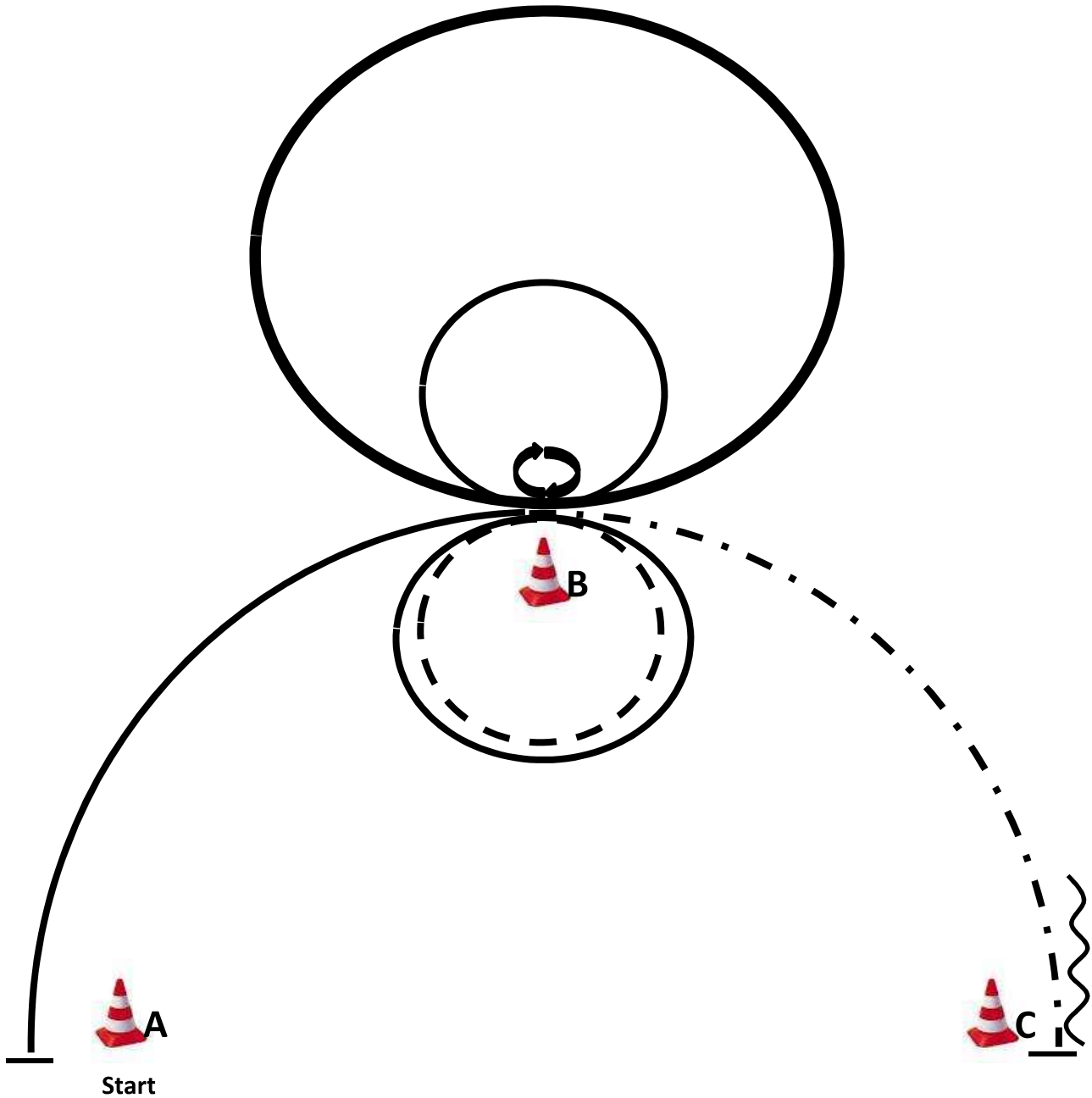

WARM UP AREA

1. Be ready at A, lope right lead to B, stop.
2. 360° turn (opt. r/l).
3. Lope left lead two circles, the first circle large ext. Lope.
4. The second circle small and regular lope.

5. Jog right around B.
  6. Lope right lead around B
  7. ext. Jog to C, stop.
  8. Back one horse length, stop.
- Walk to warm up area.

	Back
	Lope
	ext. Lope
	Jog
	Ext. Jog
	Walk
	Lead change flying/simple

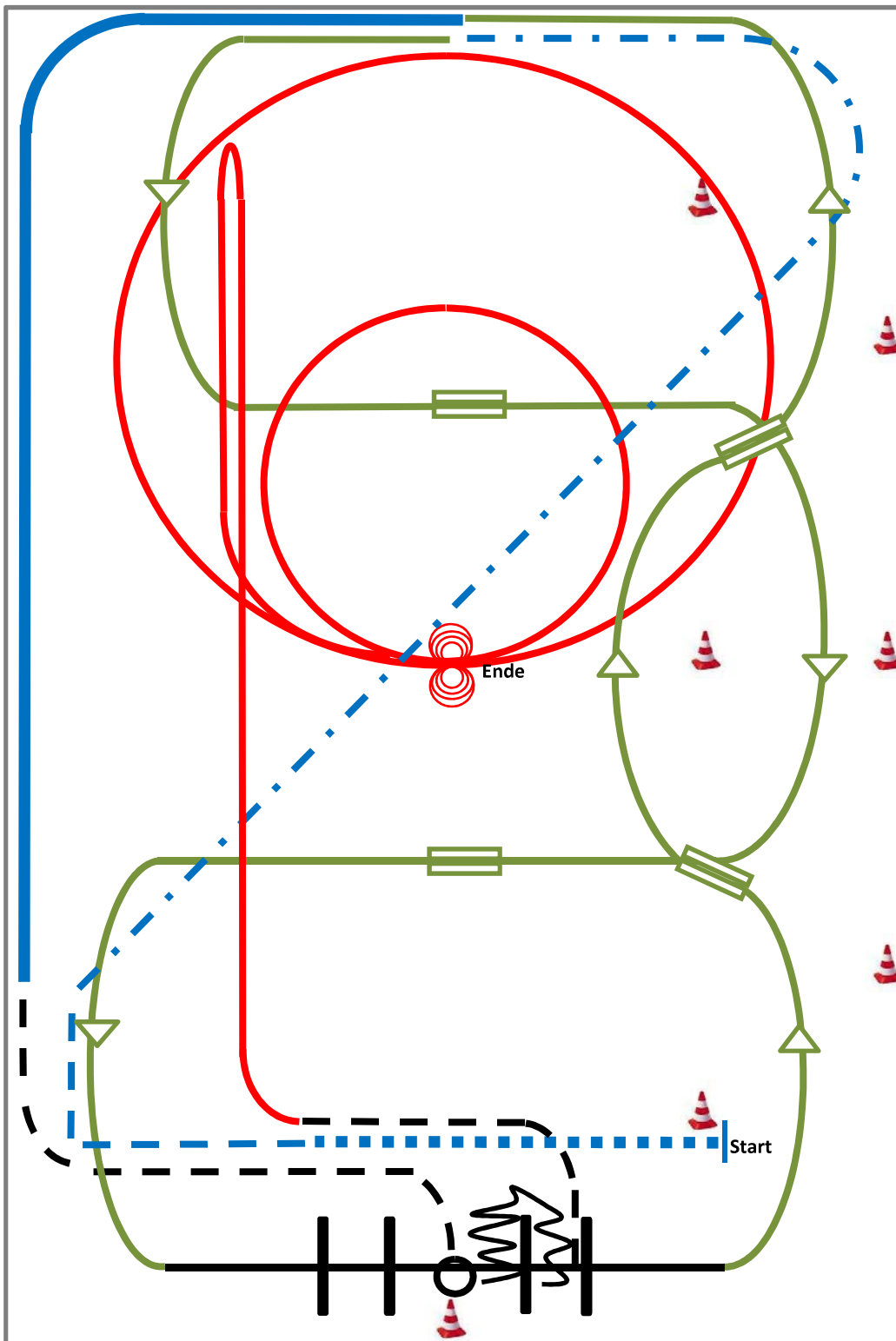

- 1) extended walk (RR)
- 2) trot, extended trot (RR)
- 3) Galoppwechsel mit Seitenwechsel (WR)
- 4) Galoppwechsel mit Seitenwechsel (WR)
- 5) lope over left lead (TH)
- 6) 2 Galoppwechsel auf der Linie (WR)
- 7) extended lope (RR)
- 8) jog, jog in, 360° turn either way (TH)
- 9) back up, jog out (TH)
- 10) Rechtsgalopp, run down entlang der langen Seite, sliding stop mind. 6m von der Bande entfernt hinter dem Mittelmarker, rollback links, kein Verharren (RN)
- 11) 2 Zirkel Galopp (links), 1 groß und schnell, 2.klein und langsam (RN)
- 12) 4 spins links, 4 spins rechts (RN)

	Back
	Lope
	Jog/Trot
	Walk
	Lead change flying/simple

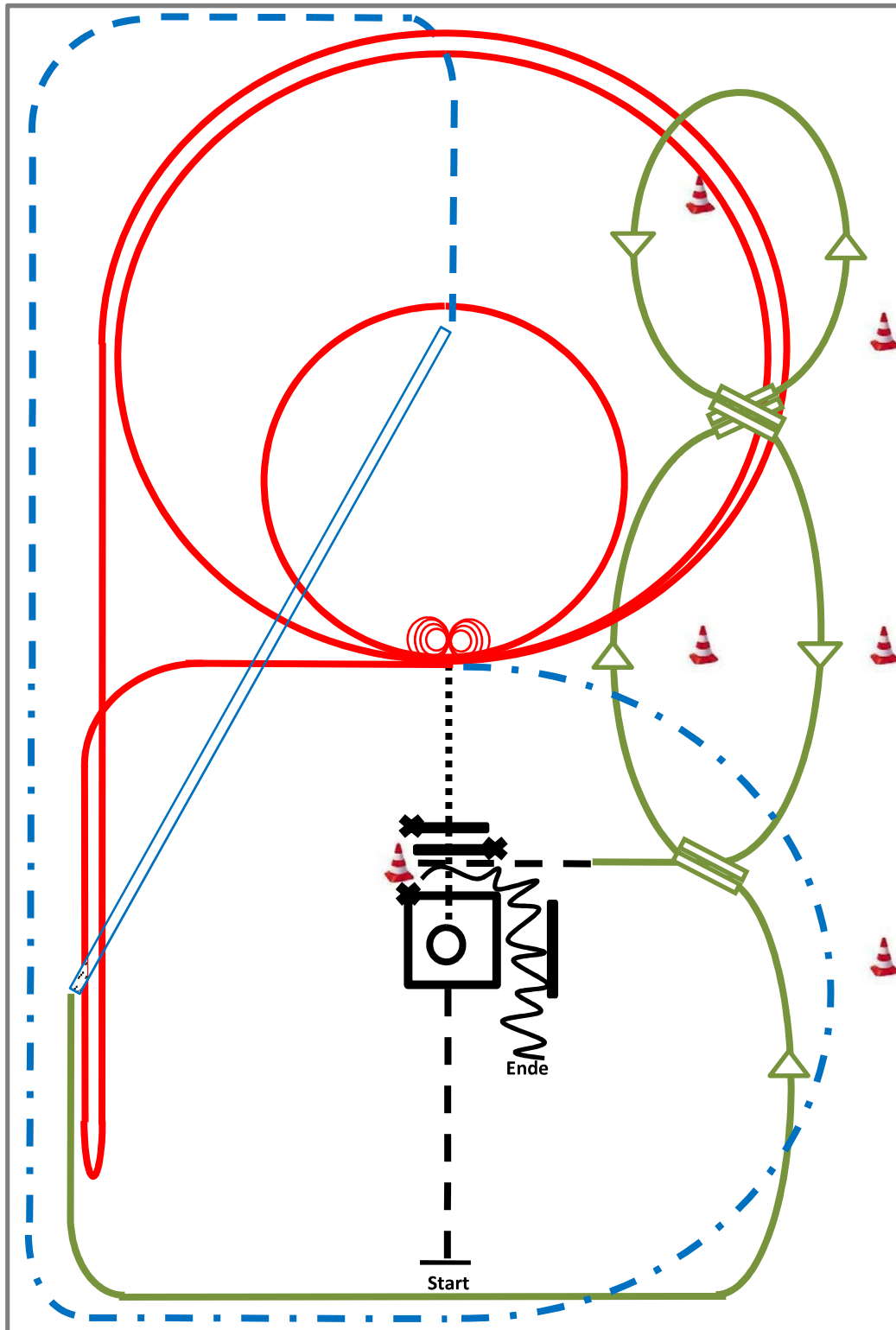

- 1) jog, jog in, 360° turn either way (TH)
- 2) walk out and walk over (TH)
- 3) 4 spins links, 4 1/4 spins rechts (RN)
- 4) 2 Zirkel Galopp (links), 1 groß und schnell, 2.klein und langsam (RN)
- 5) Galopp (links) auf dem Zirkel, der nicht geschlossen wird, run down entlang der langen Seite, sliding stop mind. 6m von der Bande entfernt hinter dem Mittelmarker, rollback rechts, kein Verharren lope bis X. (RN),
- 6) extended trot (RR)
- 7) trot corners (RR)
- 8) two track rechts (RR)
- 9) Galoppwechsel auf der Linie (WR)
- 10) Galoppwechsel auf der Linie (WR)
- 11) Galoppwechsel auf der Linie (WR)
- 12) jog in, backup (TH)

	Back
	Lope
	Jog/Trot
	Walk
	Lead change flying/simple

# 1. Pattern Trail (P-TH) für P-LK-2

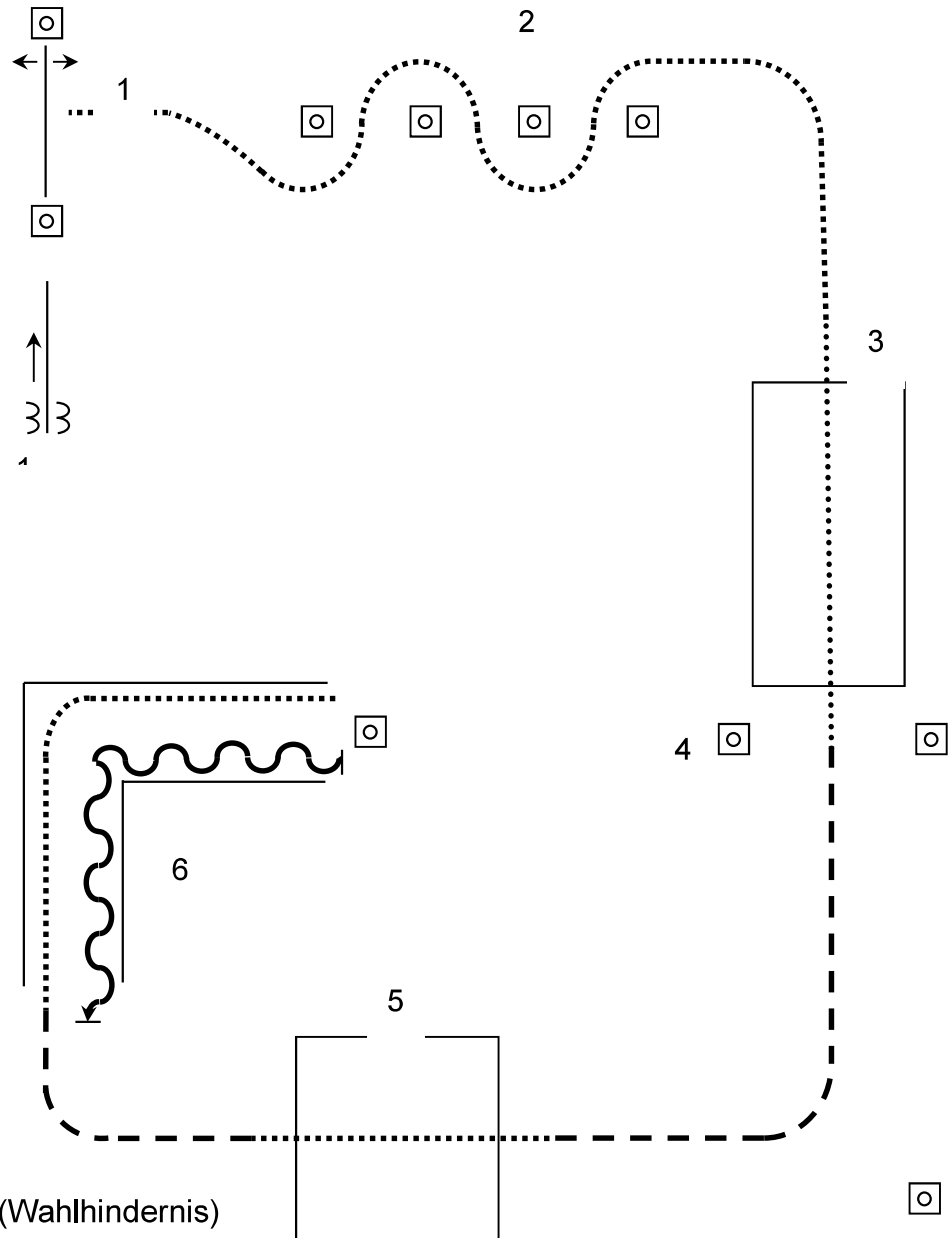

Start vor Hindernis 1 (Wahlhindernis)

- 1a Tor
- 1b Sidepass links über die Stange,  
Sidepass rechts über die Stange
- 2 Walk durch die Pylonen bis zur Brücke
- 3 Walk über die Brücke
- 4 Bei den Markern Jog bis kurz vor das Quadrat
- 5 Walk gerade durch das Quadrat kurz danach Jog  
bis kurz vor das L
- 6 Walk durch das L bis vor den Marker  
Back-Up durch das L

## 2. Pattern Westernhorsemanship (P-WHS) für P-LK-2

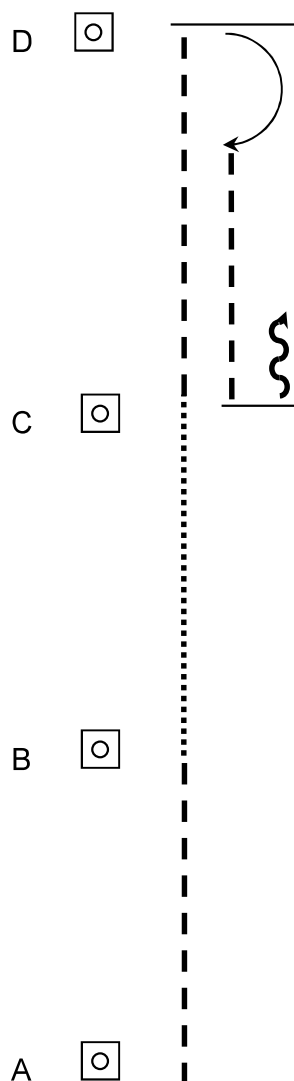

Start neben Punkt A

Von A nach B Jog

Von B nach C Walk

Von C nach D Jog

Bei D Stop

Hinterhandwendung rechts 180°

Von D nach C Jog

Bei C Stop

6 Tritte Back-Up

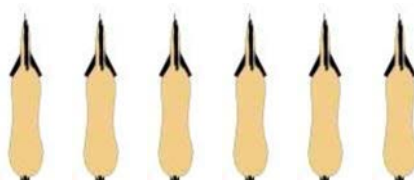



# Horse & Dog Trail LK 1-2 2016#2

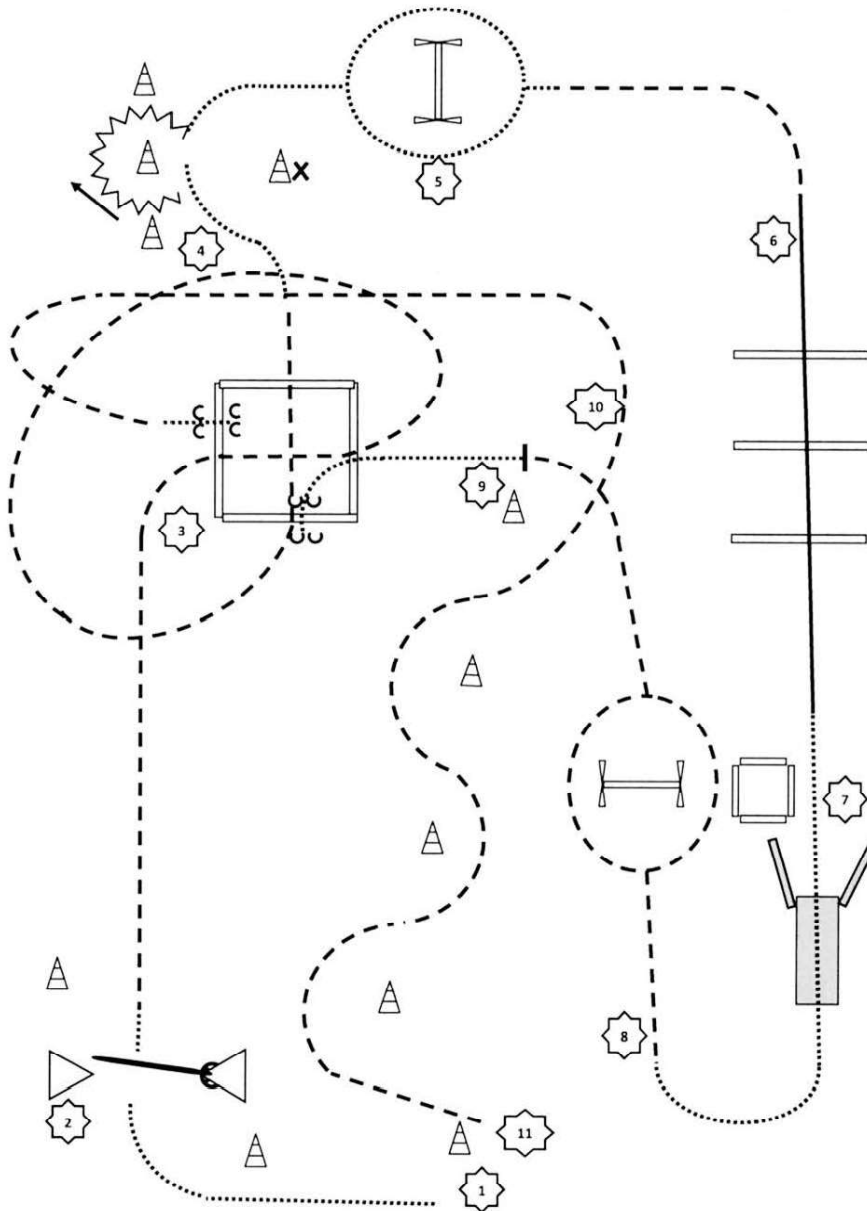



# Horse & Dog Trail LK 1-2 2016#2

	Pferd & Reiter	Hund
1	An Pylone anhalten, Walk zu 2.	Hund ableinen. Hund bei Fuß.
2	Tor rückwärts öffnen, Tor schließen. Walk . Jog zu 3.	Hund an Pylone ablegen. Hund durch das Tor abrufen, zur Pylone schicken, ablegen. Hund bei Fuß.
3	Jog over. Walk zu 4.	Hund bei Fuß durch Box. Hund bei Fuß.
4	Back up. Walk zu 5.	Hund an Pylone mit dem X ablegen. . Hund bei Fuß.
5	Walk li. oder re. am Sprung vorbei . Jog zu 6.	Hund springt, Hund bei Fuß.
6	Lope over 3 Stangen. Walk zu 7.	Hund bei Fuß. Hund bei Fuß.
7	Walk über die Brücke. Walk zu 8.	Hund in Box ablegen. Hund über die Brücke abrufen. Hund bei Fuß.
8	Jog li. oder re. am Sprung vorbei . Jog zu 9.	Hund springt über den Sprung. Hund bei Fuß.
9	An Pylone anhalten. Walk over, Sidepass rechts. Walk out. Jog zu 10.	Hund bei Pylone ablegen. Hund durch die Box abrufen. Hund bei Fuß.
10	Jog Slalom. Jog zu 11.	Hund bei Fuß. Hund bei Fuß.
11	Anhalten, absteigen.	Hund anleinen.

**Erklärung:**

Sprung sollte 20 cm bis 40 cm hoch sein  
( erhöhte Stange, Cavaletti, o.ä.).

# Horse&Dog Trail LK 3-5 2016#2

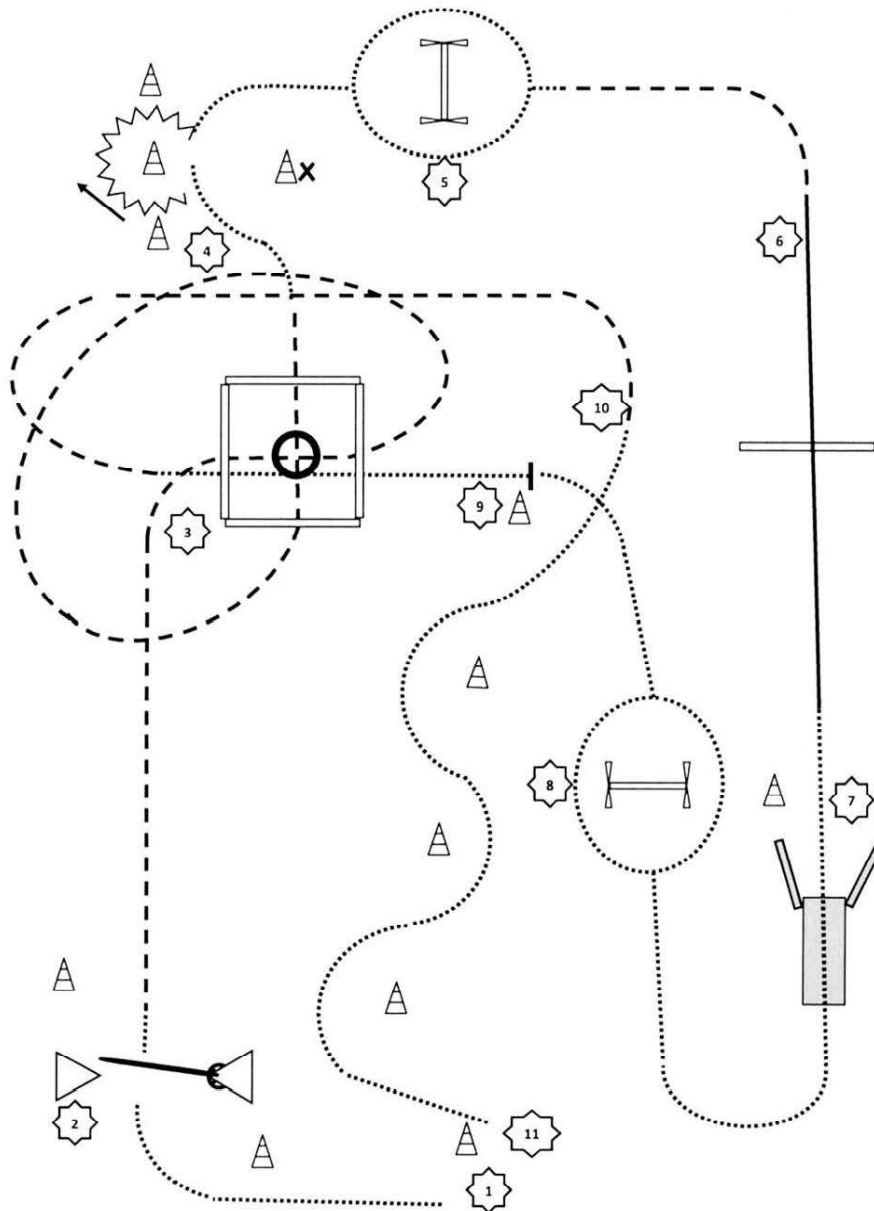

# Horse & Dog Trail LK 3-5 2016#2

	Pferd & Reiter	Hund
1	An Pylone anhalten. Walk zu 2.	Hund ableinen. Hund bei Fuß.
2	An Pylone halten. Tor beliebig öffnen, durchreiten, weit öffnen. Tor schließen. Walk, Jog zu 3.	Hund an Pylone ablegen. Hund durch das Tor abrufen, zur Pylone schicken, ablegen. Hund bei Fuß.
3	Jog over. Walk zu 4.	Hund bei Fuß durch Box. Hund bei Fuß.
4	Back up. Walk zu 5.	Hund an Pylone mit dem X ablegen. . Hund bei Fuß.
5	Walk li. oder re. am Sprung vorbei . Jog zu 6.	Hund springt über den Sprung. Hund bei Fuß.
6	Lope over 1 Stange. Walk zu 7.	Hund bei Fuß. Hund bei Fuß.
7	Walk über die Brücke. Walk zu 8.	Hund an Pylone ablegen. Hund über die Brücke abrufen. Hund bei Fuß.
8	Walk li. oder re. am Sprung vorbei . Walk zu 9.	Hund springt über den Sprung. Hund bei Fuß.
9	An Pylone anhalten. Walk in Box, 360° Drehung. Walk out. Jog zu 10.	Hund bei Pylone ablegen. Hund durch die Box abrufen. Hund bei Fuß.
10	Walk Slalom. Walk zu 11.	Hund bei Fuß. Hund bei Fuß.
11	Anhalten, absteigen.	Hund anleinen.

**Erklärung:**

Sprung sollte 20 cm bis 40 cm hoch sein  
 ( erhöhte Stange, Cavaletti, o.ä.).

# Circle L Wenden Classic

## Ranch Trail LK 3-5

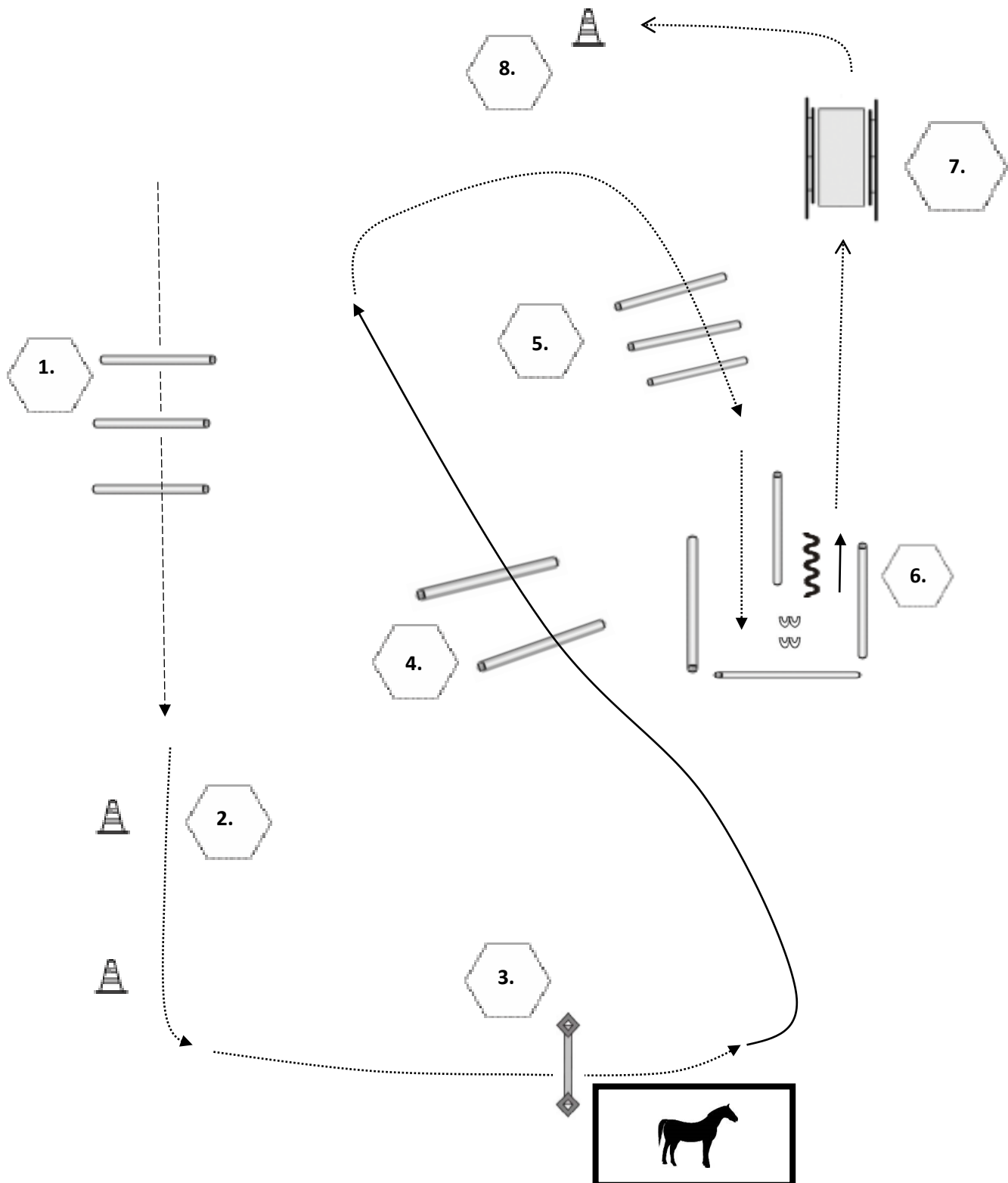

1. Im Trab über die Stangen
3. Im Schritt durch das Tor
5. Schritt über die Stangen
7. Im Schritt über die Brücke

2. Im Schritt Korb von Pylone zu Pylone transportieren
4. Galopp über die Stange
6. Vorwärts – Seitwärts – Rückwärts, Drehung
8. Stop

# Circle L Wenden Classic

## Ranch Trail LK 1-2

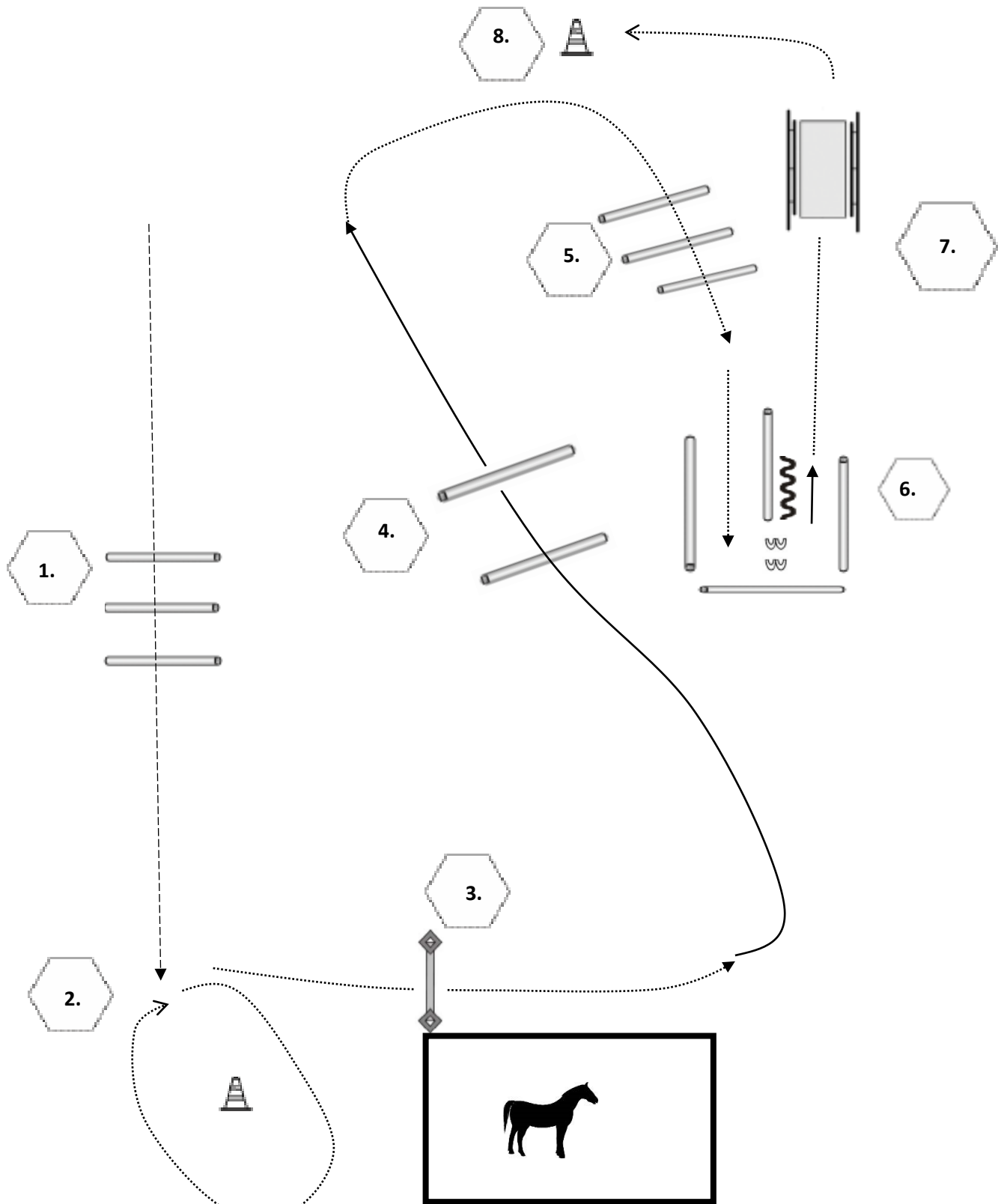

1. Im Trab über die Stangen
3. Im Schritt durch das Tor
5. Schritt über die Stangen
7. Im Schritt über die Brücke

2. Im Schritt Baumstamm ziehen um die Pylone
4. Galopp über die Stange
6. Vorwärts – Seitwärts – Rückwärts, Drehung
8. Stop

## EWU Wenden Classic Regelbuchpattern

### Reining:

Quali LK 1/2A Senior:	Pattern # 9
LK 1/2A Senior:	Pattern # 6
Quali LK 1/2 A Junior:	Pattern # 4
LK 1/2 A Junior:	Pattern # 2
LK 4:	Pattern # 14
LK 3:	Pattern # 1
LK 4 B:	Pattern # 14
LK 1/2 B:	Pattern # 6
Quali LK 1/2 B:	Pattern # 9
Youngstar:	Pattern # 5

### Western Riding:

Quali LK 1/2 A+B Senior:	Pattern # 2
LK 2/3 A Senior:	Pattern # 6
Quali LK 1/2 A Junior:	Pattern # 7
LK 1 A Senior:	Pattern # 8